



IBM System z

## Linux on System z – A Strategic View

<http://www.vm.ibm.com/devpages/jelliott/events.html>

**Jim Elliott**  
**Consulting Sales Specialist –**  
**System z New Workloads**  
**IBM Canada Ltd.**



**The Future Runs on System z**

IBM Systems

## 9202 – Linux on System z – A Strategic View

- **Datacenters planning to adopt Linux have a key architectural choice to make in designing large-scale implementations**
- **Is the best approach to running Linux scale-out with rack-optimized servers, to scale up with large SMP servers using virtualization facilities to run many images on a single server?**
- **For many users, Linux on IBM System z may be the optimal choice**
- **Jim will describe how Linux on System z, in combination with z/VM, will provide a robust Linux environment which integrates well with z/OS, z/TPF and z/VSE**

## Agenda

- **Linux on System z overview**
- **Linux on System z deployment criteria**
- **Linux distributions**
  - Novell
  - Red Hat
- **IBM Transformation: Major IT Consolidation Initiative**
- **Additional information about Linux on System z**





IBM System z

# Linux on System z overview



**The Future Runs on System z**

IBM Systems



# Take back control of your IT infrastructure

*A data center in a box – not a server farm*

- **Central point of management**
- **Increased resource utilization**
- **Potentially lower cost of operations**
  - Less servers
  - Fewer software licenses
  - Fewer resources to manage
  - Less energy, cooling and space
- **Fewer intrusion points**
  - Tighter security
- **Fewer points of failure**
  - Greater availability

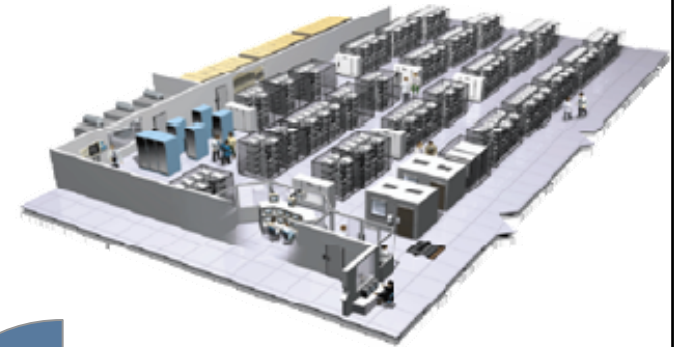

## Linux on IBM System z

*Linux + Virtualization + System z = SYNERGY*

- **The legendary IBM mainframe – IBM System z**
  - Legendary dependability
  - Extremely security-rich, highly scalable
  - Designed for multiple diverse workloads executing concurrently
  - Proven high volume data acquisition and management
- **The IBM mainframe virtualization capabilities – z/VM**
  - Support for large real memory and 32 processors
  - Enhanced security and LDAP server/client
  - Enhanced memory management for Linux guests
  - Enhanced management functions for Linux
- **Open standards operating system – Linux for System z**
  - Reliable, stable, security-rich
  - Available from multiple distributors
  - Plentiful availability of skills administrators and developers
  - Large selection of applications middleware and tooling from IBM, ISVs and Open Source

## What is Linux on System z?

- **A native mainframe operating environment**
  - Exploits IBM System z hardware
  - Not a unique version of Linux
- **Application sourcing strategy**
  - The IBM commitment to z/OS, z/VSE and z/TPF is not affected by this Linux strategy
  - Customers are offered additional opportunities to leverage their investments through Linux
  - New doors are opening for customers to bring Linux-centric workloads to the platform

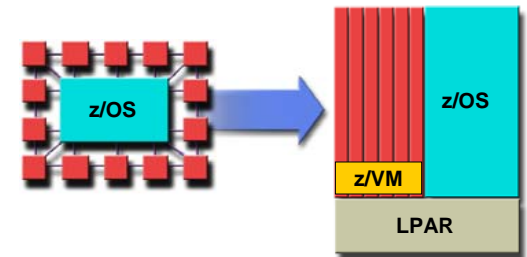
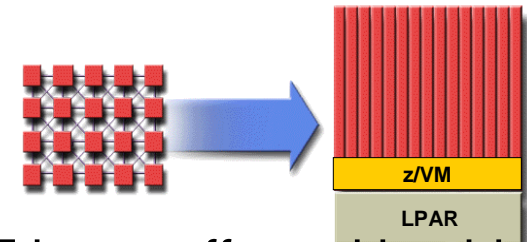

## What System z brings to Linux

- **The most reliable hardware platform available**
  - Redundant processors and memory
  - Error detection and correction
  - Remote Support Facility (RSF)
- **Centralized Linux systems are easier to manage**
- **Designed to support mixed work loads**
  - Allows consolidation while maintaining one server per application
  - Complete work load isolation
  - High speed inter-server connectivity
- **Scalability**
  - System z10 EC scales to 64 application processors
  - System z9 EC scales to 54 application processors
  - System z9 BC scales to 7 application processors
  - Up to 11 (z10 EC), 8 (z9 EC) dedicated I/O processors
  - Hundreds of Linux virtual servers



## What is different about Linux on System z?

- **Access to System z specific hardware**
  - Crypto support – CPACF, Crypto2
  - Traditional and Open I/O subsystems
    - Disk (ECKD or SCSI) and tape
    - SAN Volume Controller
  - OSA-Express, OSA-Express2 and OSA-Express3 for very high speed communication between z/OS and Linux
  - HiperSockets for ultra-high speed communication between z/OS and Linux on the same machine
- **z/VM aware**
  - Enhanced performance
  - System management tools

## Value of Linux on System z

- **Reduced Total Cost of Ownership (TCO)**
  - Environmental savings – single footprint vs. hundreds of servers
  - Consolidation savings – less storage, less servers, less software licenses, less server management/support
- **Improved service level**
  - Systems management (single point of control)
  - Reliability, availability, security of System z
  - High performance integration with z/OS, z/VSE, z/TPF
- **Speed to market**
  - Capacity-on-demand capability on System z
  - Dynamic allocation of on-line users, less than 10 seconds to add a new Linux server image using z/VM and IBM DS8000

## System z – The ultimate virtualization resource

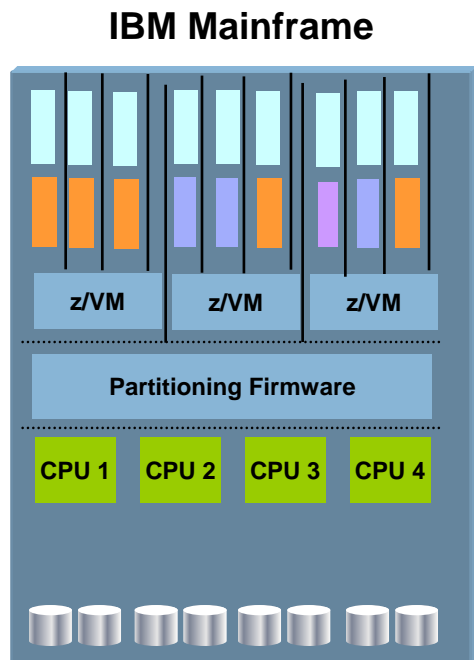

- **Utilization often exceeds 90%**
  - Handles peak workload utilization of 100% without service level degradation

- **Massive consolidation platform**
  - Up to 60 logical partitions, 100s to 1000s of virtual servers under z/VM
  - Virtualization is built-in, not added-on
  - HiperSockets for memory-speed communication
  - Most sophisticated and complete hypervisor function available
- **Intelligent and autonomic management of diverse workloads and system resources based on business policies and workload performance objectives**

## z/VM – Unlimited virtualization

- **z/VM provides a highly flexible test and production environment for enterprises deploying the latest e-business solutions**
- **z/VM helps enterprises meet their growing demands for multi-system server solutions with a broad range of support for operating system environments**
- **Mature technology – VM/370 introduced in 1972**
- **Software Hypervisor integrated in hardware**
  - Sharing of CPU, memory and I/O resources
  - Virtual network – virtual switches/routers
  - Virtual I/O (mini-disks, virtual cache, ...)
  - Virtual appliances (SNA/NCP, etc.)
- **Easy management**
  - Rapid install of new servers – cloning or IBM Director task z/VM Center
  - Self-optimizing workload management



## The value of z/VM for Linux

- **Enhanced performance, growth and scalability**
  - Server consolidation enables horizontal growth
  - N-tier architecture on two tiers of hardware
  - Extensive support for sharing resources
  - Virtual networking
  - Effective isolation of Linux images, if required
- **Increased productivity**
  - Development and testing
  - Production support
- **Improved operations**
  - Backup and recovery
  - Command and control

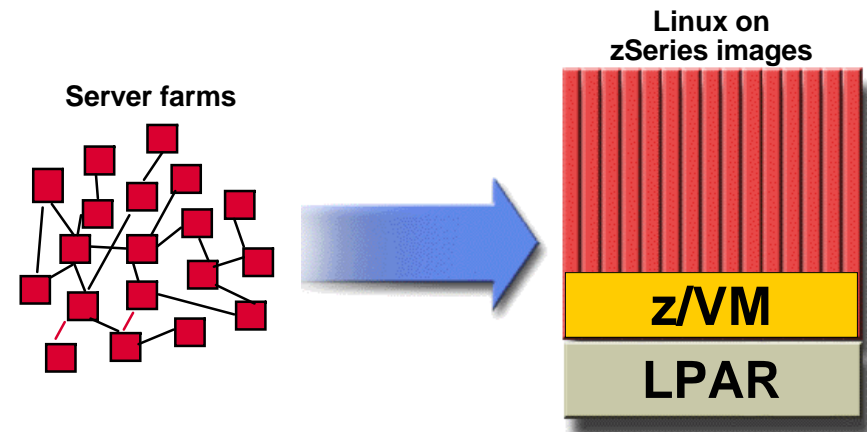



## Integrated Facility for Linux

- **Additional engines dedicated to Linux workloads**
  - Supports z/VM and Linux on System z
  - IFLs on “sub-uni” systems run at “full speed”
    - z800, z890, z9 EC, z9 BC, z10 EC
- **Traditional mainframe software charges unaffected**
  - IBM mainframe software
  - Independent Software Vendor products
- **Linux and z/VM charged only against the IFLs**

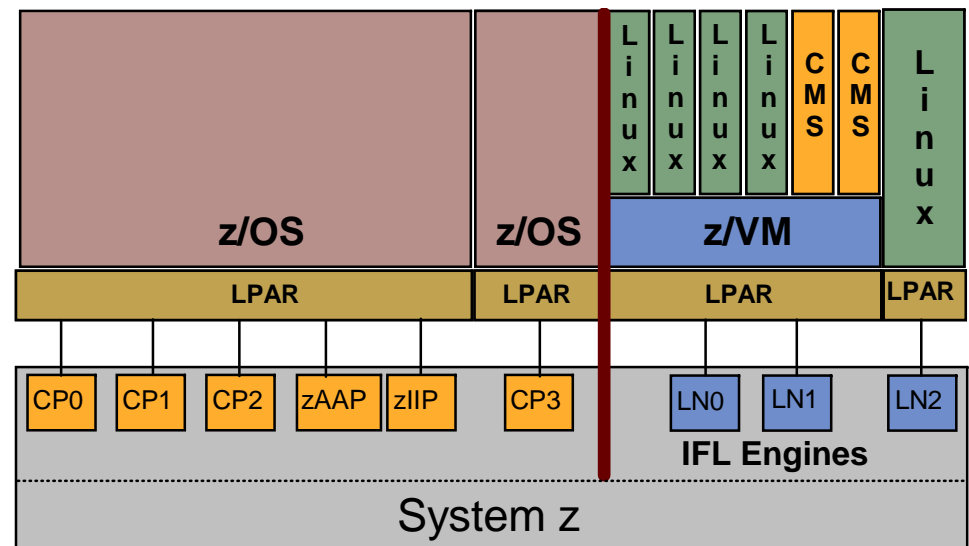

# Application serving with Linux on System z

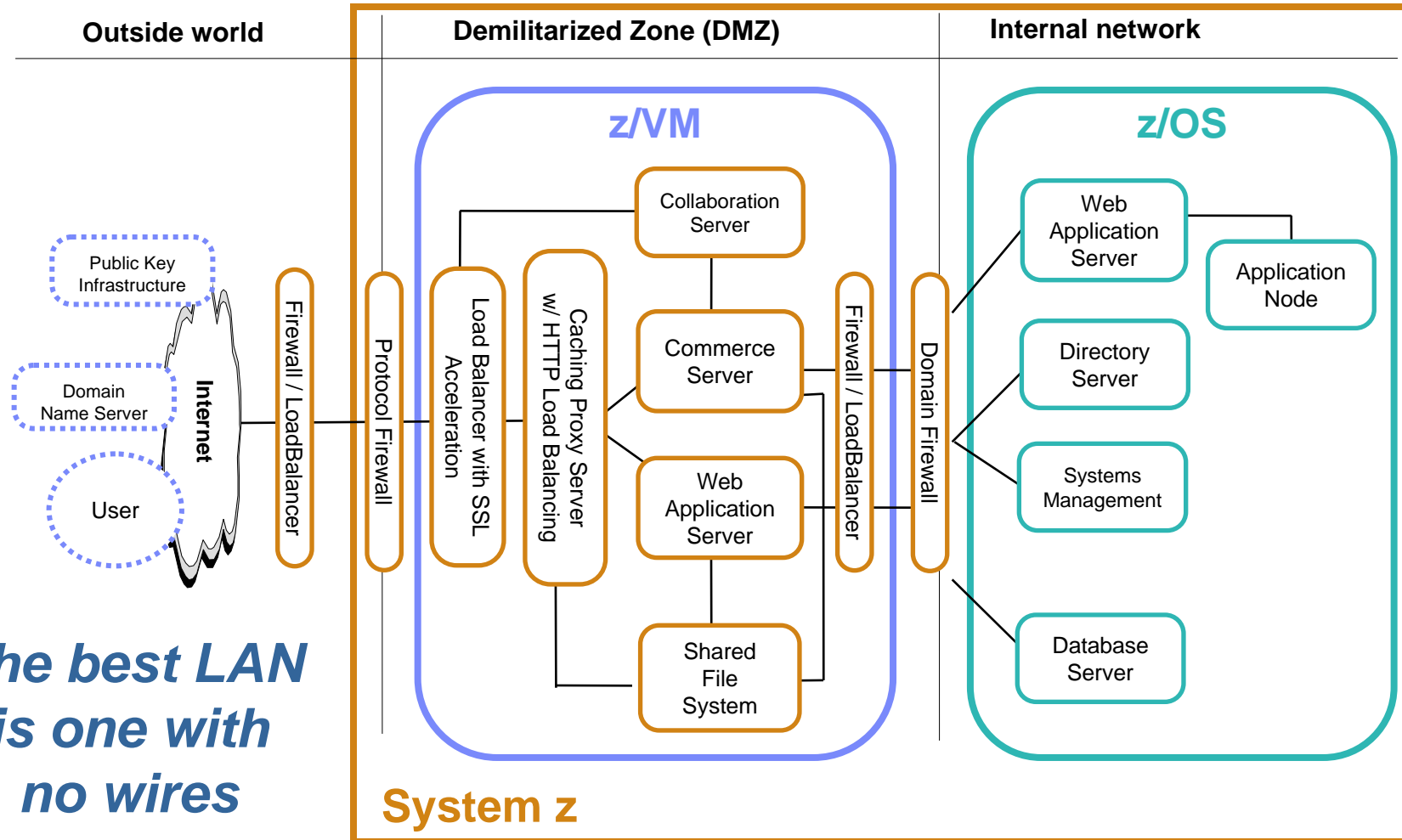

*The best LAN  
is one with  
no wires*

**System z**



IBM System z

## Linux on System z deployment criteria



**The Future Runs on System z**

IBM Systems

# Infrastructure simplification

- Customers leveraging scale up and scale out technologies to simplify and integrate their on demand operating environment
- As one solution option:
  - Large SMP and Rack Optimized servers integrated with Linux, Java and Grid technologies can enable this transformation

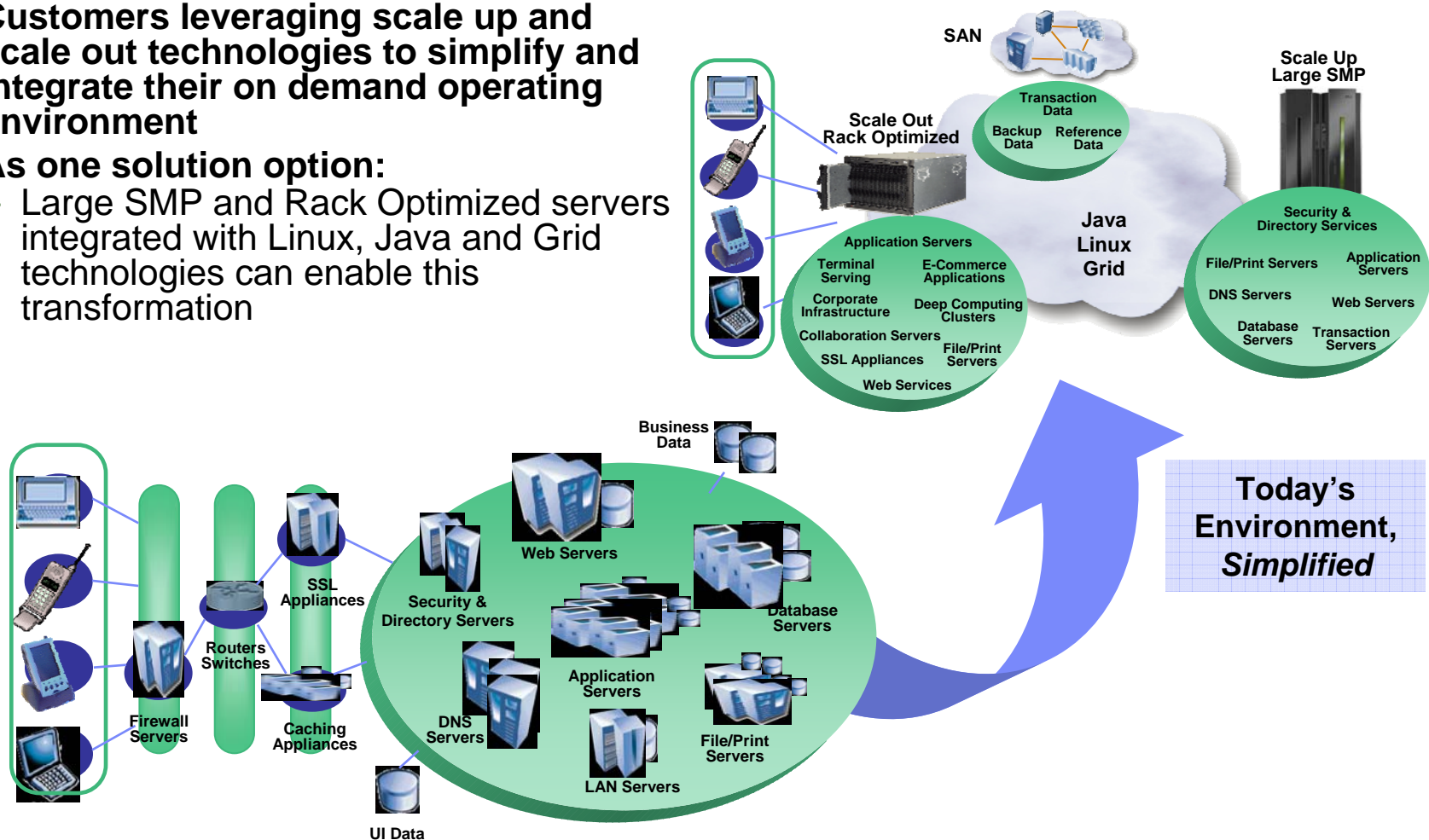

# Ideal blade implementations

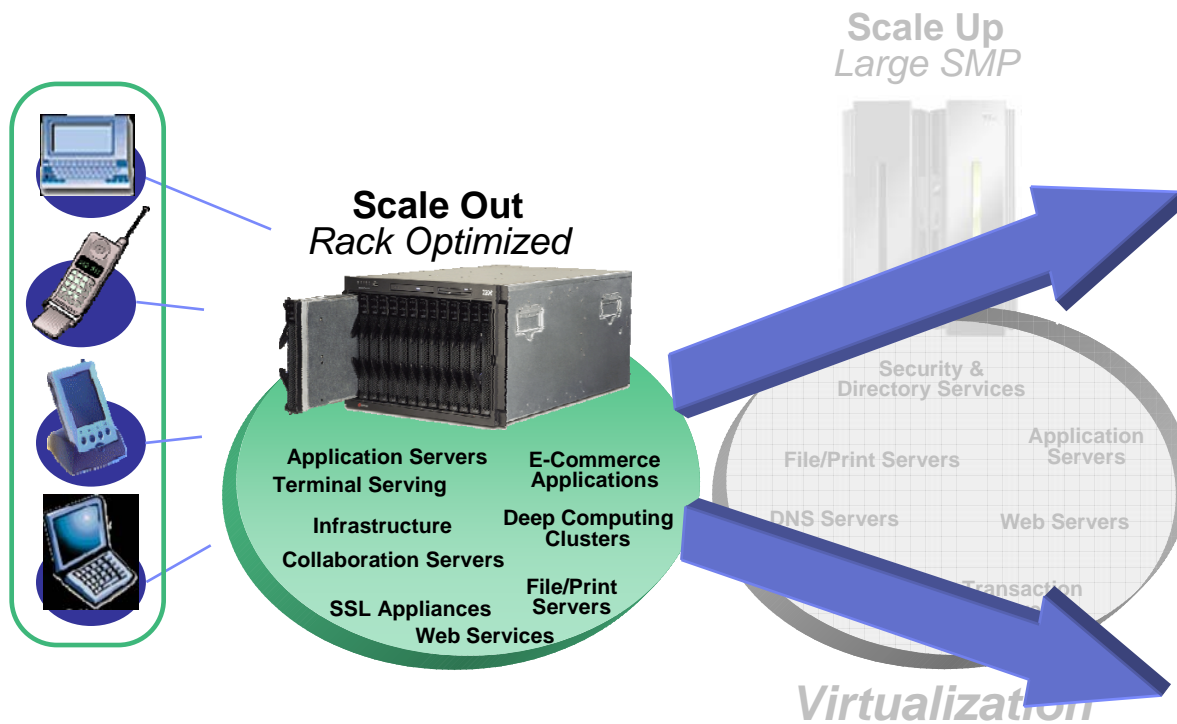

- **Clustered workloads**
- **Distributed computing applications**
- **Infrastructure applications**
- **Small database**
- **Processor and memory intensive workloads**
- **Centralized storage solutions**



# Ideal mainframe implementations

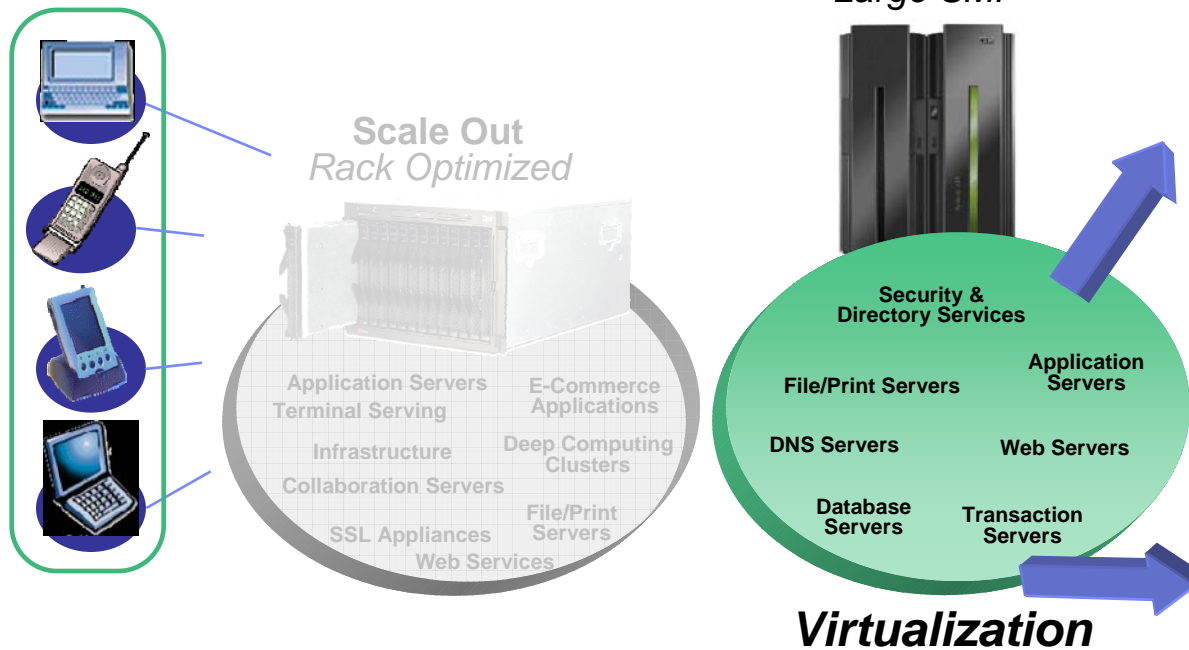

- High performance transaction processing
- I/O intensive workloads
- Large database serving
- High resiliency and security
- Unpredictable and highly variable workload spikes
- Low utilization infrastructure applications
- Rapid provisioning and re-provisioning

## Selecting an application

- **Performance on System z CPUs is comparable to CPUs on other platforms of similar speed**
  - CPU speed is not the entire story – it's in the architecture!
  - Architecture designed for multiple or consolidated workloads
  - System z has definite advantage with applications that have mixed CPU and I/O
- **System z and z/VM provide excellent virtualization capabilities**
  - Look for applications that are on lower utilized servers
  - Development and Test are good choices to start
- **Good planning is essential**
- **IBM can**
  - Perform sizing estimates
  - Assist with planning and initial installation needs



## Where to deploy on System z – z/OS or Linux?

### Technical Considerations

---

Linux → z/OS

Quality of Service

---

Linux ← z/OS

Speed of deployment

---

Linux ← z/OS

Degree of portability

### Other Considerations

---

- Application availability
- Workload Management function and granularity
- File sharing across a Sysplex
- Manageability and scaling characteristics
- Availability of skill

## Where to deploy – System z or “distributed”

### Technical Considerations

---

System z      ←      “distributed”  
Quality of Service

---

System z      ←      “distributed”  
Speed of deployment  
Instances 2 - n

---

System z      ←      “distributed”  
Data Intensity

---

System z      →      “distributed”  
Compute Intensity

### Other Considerations

---

- **Application availability**
  - Certification of solution on hardware/software platform
- **Workload Management**
- **Manageability and scaling characteristics**
  - Especially DB2 and WebSphere on z/OS
  - Proximity of data to application
  - The best network is an internal network!

## Workload share on utilized IFLs

*Primary application*

<b>60%</b>	<b>Application serving for systems</b> e.g. WebSphere, SAP, CICS TG, JBoss, DB2 Connect
<b>30%</b>	<b>Data serving</b> e.g. Oracle DB, DB2 UDB, MySQL, Informix, ...
<b>5%</b>	<b>Workplace serving</b> e.g. Domino, Scalix, ...
<b>5%</b>	<b>Infrastructure serving</b> e.g. Apache, Samba, NFS, ...
<b>&lt;1%</b>	<b>Linux application development/deployment</b>

Notes: extrapolation based on analyzing 1/3 of inventory, excludes all IBM. February 2006



## Linux on IBM System z

*Take back control of your IT infrastructure*

- **Unify the infrastructure**
  - IT optimization and server consolidation based on virtualization technology and Linux
  - Linux can help to simplify systems management with today's heterogeneous IT environment
- **Leverage the mainframe data serving strengths**
  - Deploy in less time, accessing core data on z/OS
  - Reduced networking complexity and improved security network “inside the box”
- **A secure and flexible business environment**
  - Linux open standards support for easier application integration
  - Unparalleled scale up / scale out capabilities
  - Virtual growth instead of physical expansion on x86 or RISC servers
- **Leverage strengths across the infrastructure**
  - Superior performance, simplified management, security-rich environment
  - High-performance security-rich processing with Crypto2 cryptographic co-processors
  - Backup and restore processes





IBM System z

**Novell.**

*[www.novell.com/products/server/](http://www.novell.com/products/server/)  
[www.novell.com/partners/ibm/mainframe/](http://www.novell.com/partners/ibm/mainframe/)*



**The Future Runs on System z**

IBM Systems

## Customer pain points

- **Increasing TCO**
  - Mainframes use 20% of space/power of distributed systems
- **Increasing data center complexity**
  - Reduce number of vendors, software/hardware licenses/contracts, system admins, management tools
- **Decrease in flexibility**
  - Add new workloads in minutes
- **Costly downtime**
  - Mainframes reduce downtime with redundancy

## Market stats

- **More than 1,600 applications available for Linux for System z**
  - Over 400 ISVs
  - Includes many IBM middleware offerings
  - Includes many open source offerings
- **50% of largest mainframe customers use Linux**



## SUSE Linux Enterprise Server 10 SP2

*New features: System z*

- **Kernel NSS support**
- **External time reference support**
- **Support for processor degradation**
- **Provide Linux process data into z/VM monitor stream**
- **Linux CPU node affinity**
- **Large page support (1MB pages)**



## ISV Applications Update

- **Novell® ISV certifications program team**
- **Targeted ISV application list — most important at all times**
- **Novell ISV catalog online**
- **Certified ISV applications growing at double digit rates**



## SUSE Linux Enterprise Server 10 SP2 Starter System for System z?

- **Historically, one of the biggest hurdles to implementing Linux on the mainframe has been gaining network access to the installation media from the mainframe:**
  - Installation routines cannot access built-in DVD reader
  - Firewall rule changes needed
- **SUSE Linux Enterprise Server Starter System for System z eliminates this hurdle for customers running z/VM**
- **9287 Installing a Novell SLES 10 Starter System without a Net(work)**
- **Thu, 1:30pm, Convention Center, Concourse Level, Room D**



## SUSE Linux Enterprise Server 10 SP2 for System z: A Winning Combination

- **Proven capability to significantly lower TCO**
  - Nationwide, Deutsche Bahn and others
- **Rich security, stability, flexibility, and interoperability**
- **Enterprise virtualization platform**
  - Reduces data center complexity
  - Reduces downtime
  - Improves flexibility, allowing business needs to be met
  - Virtualization and workload management unifies your infrastructure
  - Faster, more secure communication among servers
  - As you add workloads, the cost per virtual server drops



## SUSE Linux Enterprise Server 10 SP2 for System z Resources

- **Marketing Website**
  - Consolidate and virtualize servers, while leveraging efficiencies of Linux, for greater availability and lower TCO
  - <http://www.novell.com/linux/mainframe>
- **Starter System for System z**
  - Simplify Deployment of Linux on the mainframe with SUSE Linux Enterprise Server for System z
  - <http://www.novell.com/partners/ibm/mainframe/starterpack.html>
- **Download SUSE Linux Enterprise Server for System z**
  - Simplify Deployment of Linux on the mainframe with SUSE Linux Enterprise Server for System z
  - <http://www.novell.com/products/server/eval.html>

## z/VM and Linux on IBM System z: The Virtualization Cookbook for SLES 10 SP2

- This book describes how to roll your own Linux virtual servers on IBM System z hardware under z/VM.
- It adopts a cookbook format that provides a concise, repeatable set of procedures for installing and configuring z/VM in an LPAR and then installing and customizing Linux.
- To follow along with this book, you will need an IBM System z logical partition (LPAR) with associated resources, z/VM 5.3 media, and a Linux distribution.

<http://www.redbooks.ibm.com/redpieces/abstracts/sg247493.html>

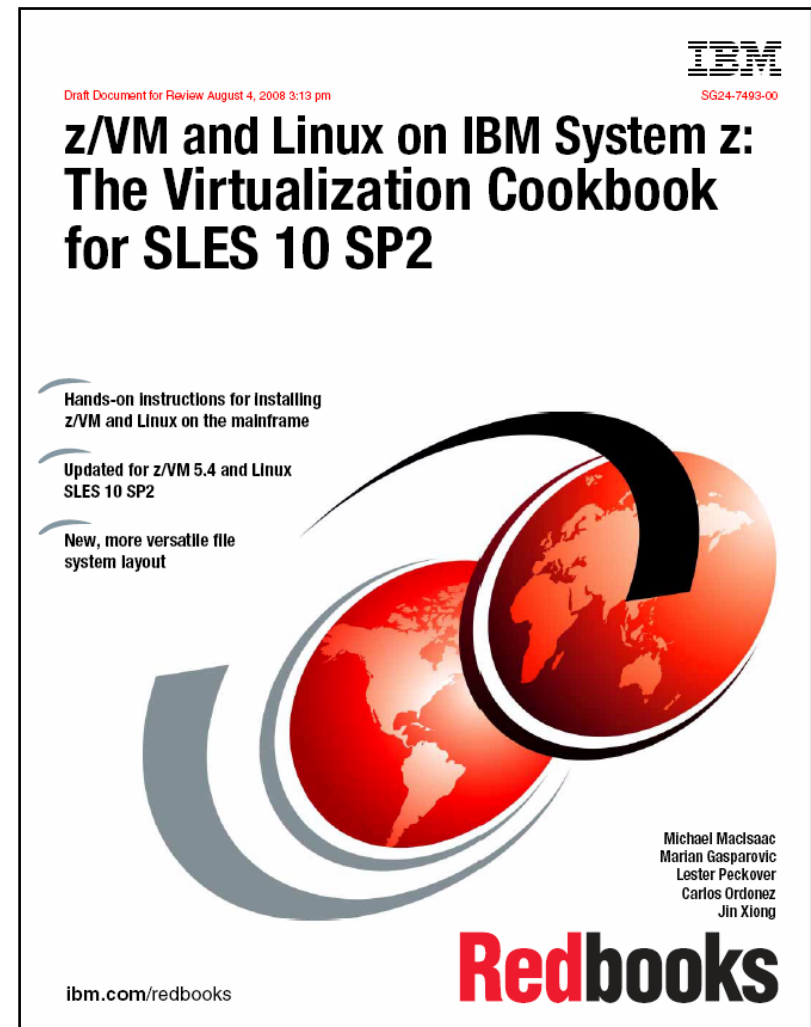



IBM System z



[www.redhat.com/rhel/server/](http://www.redhat.com/rhel/server/)

[www.redhat.com/rhel/server/mainframe/](http://www.redhat.com/rhel/server/mainframe/)

**The Future Runs on System z**

IBM Systems



## Red Hat Enterprise Linux 4.7

*Announced Thursday, July 24 2008*

- **2.6.9-78 Kernel Stream**
- **Added AIDE**
- **Ability to generate SHA-256 and SHA-512 password hashes**
- **Updated zFCP driver to include bugfixes**
- **Updated qdio driver to fix zFCP/SCSI write to IO stagnates on LPAR**
- **/proc/sys/vm/nfs-writeback-lowmem-only param to fix NFS read performance**
- **/proc/sys/vm/write-mapped to help select faster NFS read performance**
- **autofs5**
- **N\_PIV is waiting development acceptance for 4.8 (Already in RHEL5)**
- **[https://rhn.redhat.com/network/software/download\\_isos\\_full.pxt](https://rhn.redhat.com/network/software/download_isos_full.pxt)**



# Linux kernel – System z Specific Changes

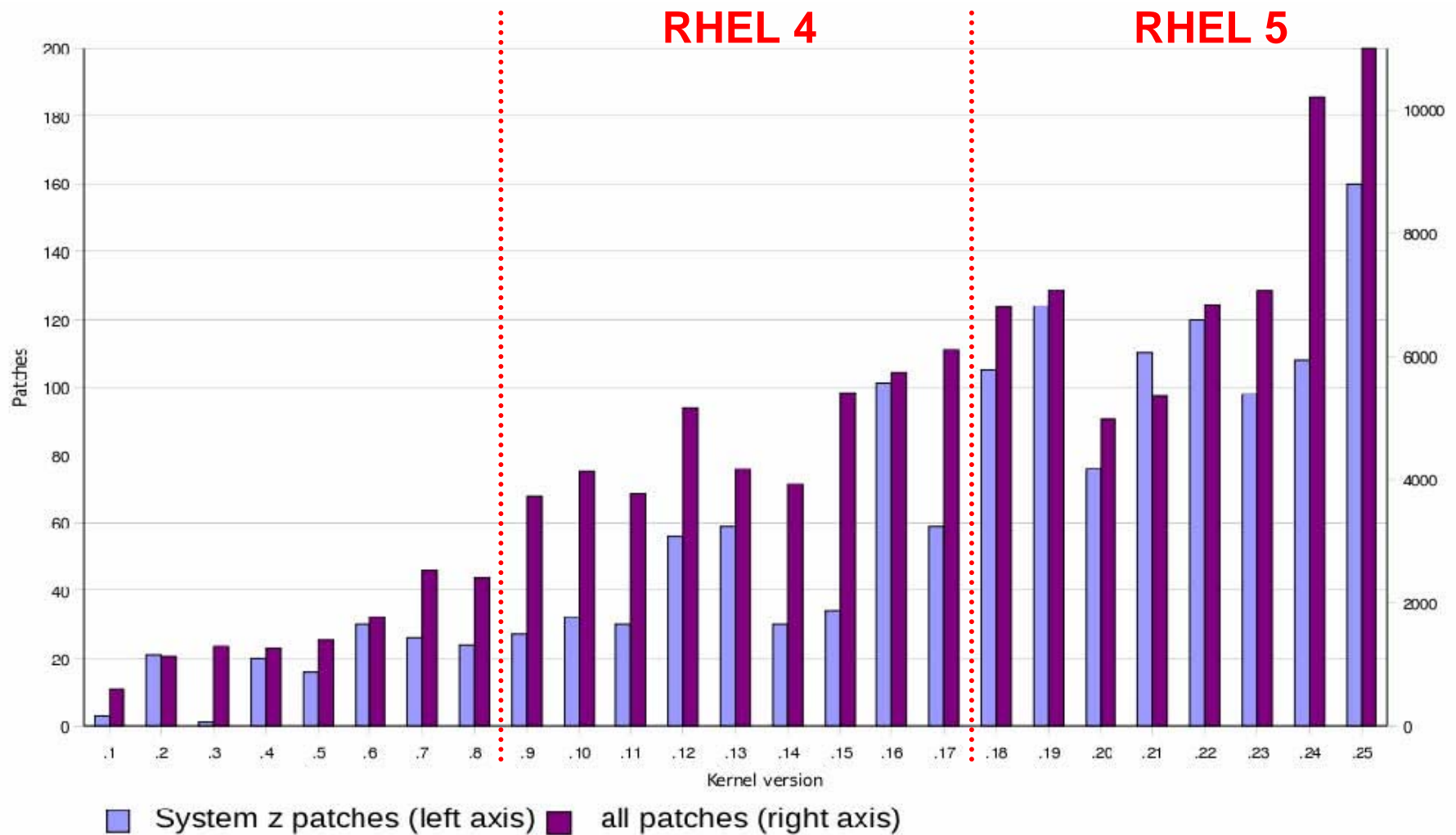

## RHEL status

- **RHEL 5.1**
  - Improved z/VM scheduling
  - Improved performance with key recompiled libraries
- **RHEL 5.2**
  - Support for new IBM z10
  - Improved IBM Director support to support fast connection to z/VM
  - Improved Virtual Server Management
  - Implementation of SCSI dump infrastructure
  - Support for Dynamic CHPID reconfiguration
  - Better network configuration tool support for System z network adapters
  - Improved install experience with support for “ssh -X” with VNC
  - Better network performance with skb scatter-gather support
  - Implemented device-multipath support for xDR/GDPS
- **RHEL 5.3**
  - NSS, CPU Affinity, ETR support planned

## RHEL status

### ■ Hardware Enablement

- In kernel crypto
  - S/390 implementation of SHA-384 and SHA-512 digests
  - Improved encryption performance (i.e. encrypted filesystems)
- libica library
  - Support for updated OpenSSL, PKCS#11, GSKit, and kernel crypto APIs
  - Device driver performance updates
- Crypto2 Express Support

## RHEL status

### ■ Kernel Enablement

- SELinux
  - Policies { targeted, strict, MLS }
  - Contexts { root:system\_r:httpd\_sys\_script\_t }
  - Roles { system\_r, object\_r }
- ExecShield, FORTIFY\_SOURCE, and Canary Values
  - kernel.exec-shield (/proc/sys/kernel/exec-shield)
- ACL Lists
  - setfacl, getfacl

## **JBoss now certified for RHEL 4 and RHEL 5 for System z!**

- **EAP 4.2 CP04 and 4.3 CP02 certified**
  - Components tested: Core EAP, ejb3, webservices, jboss messaging and hibernate
- **IBM JDK testing configurations:**
  - RHEL 4.6 x86, x86\_64 with IBM Java 1.5.0 (32-bit, 64-bit)
  - RHEL 5.2 x86, x86\_64 with IBM Java 1.5.0 (32-bit, 64-bit)
- **System z configurations:**
  - RHEL 4.5 s390 (31-bit) with IBM Java 1.5.0 (31-bit)
  - RHEL 4.5 s390x (64-bit) with IBM Java 1.5.0 (64-bit)
  - RHEL 5.0 s390x (64-bit) with IBM Java 1.5.0 (64-bit)



| IBM System z

# IBM Transformation: Major IT Consolidation Initiative



**The Future Runs on System z**

IBM Systems



## IBM Consolidation Announcement Highlights

- IBM will consolidate thousands of servers onto approximately 30 IBM System z™ mainframes
- We expect substantial savings in multiple dimensions: energy, software and system support costs
- Major proof point of IBM's 'Project Big Green' initiative
- The consolidated environment will use 80% less energy
- This transformation is enabled by the System z sophisticated virtualization capability



***Think what we could do for you***

### ***IBM'S PROJECT BIG GREEN SPURS GLOBAL SHIFT TO LINUX ON MAINFRAME***



Plan to shrink 3,900 computer servers to about 30 mainframes targets 80 percent energy reduction over five years

*Optimized environment to increase business flexibility*

**ARMONK, NY, August 1, 2007** – In one of the most significant transformations of its worldwide data centers in a generation, IBM (NYSE: IBM) today announced that it will consolidate about 3,900 computer servers onto about 30 System z mainframes running the Linux operating system. The company anticipates that the new server environment will consume approximately 80 percent less energy than the current set up and expects significant savings over five years in energy, software and system support costs.

At the same time, the transformation will make IBM's IT infrastructure more flexible to evolving business needs. The initiative is part of Project Big Green, a broad commitment that IBM announced in May to sharply reduce data center energy consumption for IBM and its clients.

## IBM infrastructure

*Continued server growth brought physical space challenges*

- **Data center efficiencies achieved**
  - Consolidation of infrastructure
  - Application consolidation/reduction
  - Enterprise architecture optimization
  - Global resource deployment
- **Next level of infrastructure challenge**
  - Floor space challenges in key facilities
  - Underutilized assets in outdated Web infrastructure
  - Continued infrastructure cost pressure

## Early modeling identified significant potential for savings through virtualization on System z

- **Performed TCO and consolidation assessment on IBM portfolio**
  - Cross-IBM effort: System z, Software Migration Services, TCO Academy, Migration Factory

### Cumulative 5 Year Cost Comparison

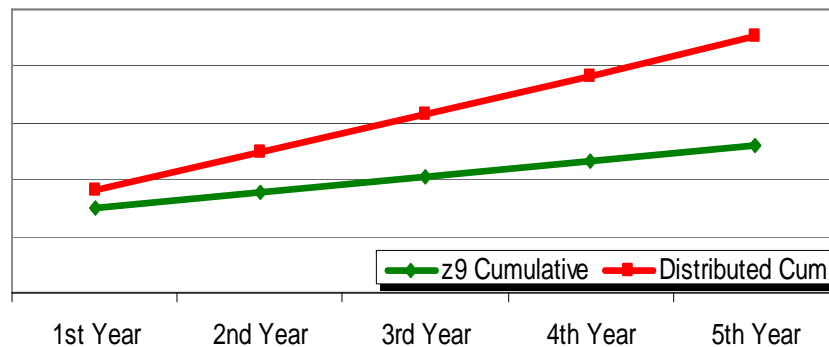

Analysis models today's steady state operations cost with projected System z operations cost

### Steady State Savings

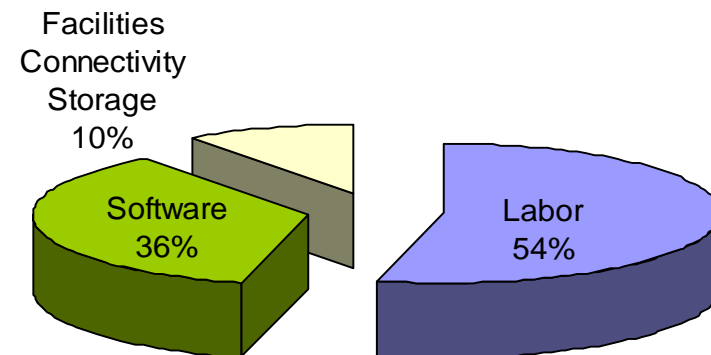

Savings are net after hardware and migration investments

- **Identified substantial savings opportunity**
  - Annual Energy Usage reduced by 80%
  - Total floor space reduced by 85%



## Successful Techniques Preparing for Virtualization

### Motivate business units

- **Enlist a Senior Executive Sponsor**
  - Sr. VP Linda Sanford, who manages Transformation for IBM is providing enterprise leadership, working with Business Unit Sr. VPs
- **Build an “incentive” rate**
  - Financial benefit provides good incentive for support and teaming in project execution. Reductions are being phased in during the project with differentiated rates.

---

### Build the business case

- **Start with a high level planning estimate**
  - Initial estimates from zRACE model were validated by the CFO through a detailed analysis of a sample subset of 325 servers

---

### Gather data

- **Augment inventories with network tools**
  - Local and central Configuration Management DB needed augmentation with network scans to gather configurations and application mapping

## Successful Techniques Project Start-up

- |  |  |
|--|--|
| <b>Start small</b>                               | <ul style="list-style-type: none"><li>▪ <b>Migrate a small set of servers for a fast start</b><ul style="list-style-type: none"><li>–An initial Phase to immediately migrate a small number of servers worked well to build early experience</li></ul></li></ul>   |
| <b>Run operations while transforming</b>         | <ul style="list-style-type: none"><li>▪ <b>Use a dedicated team</b><ul style="list-style-type: none"><li>–IBM's commercial migration practice is implementing most of the management and migration, minimizing the operational team's responsibility to Final Test, Environment Build and Cutover</li></ul></li></ul>                    |
| <b>Manage complexity</b>                         | <ul style="list-style-type: none"><li>▪ <b>Engage strong project management</b><ul style="list-style-type: none"><li>–A structured management approach and broad, sustained sponsorship from the business units are critical</li></ul></li></ul>   |
| <b>Monitor progress and continuously improve</b> | <ul style="list-style-type: none"><li>▪ <b>Use an end-to-end process approach</b><ul style="list-style-type: none"><li>–A streamlined end-to-end process approach has been established with clear interfaces and handoffs. It will be monitored and improved with process flow metrics, yield metrics and automation</li></ul></li></ul> |



## Successful Techniques Business Unit Communication

- **The CIO Office is providing leadership and communication with the Business Units:**
  - Initial CIO communication shared business objectives and commitment
  - Exceptions scrutinized by CIO
  - Regular meetings and communication with business unit application owners during migration
  - Common concerns from business units and application owners being mitigated

Top 5 Concerns	Mitigation
<b>Will my bill go up? How much will it be?</b>	Implementing tiered rates: base cost plus variable usage. Rates will accurately reflect cost to the corporation
<b>Have there been any successful pilots?</b>	Accepting volunteer applications initially. CIO migrating most visible internal application: IBM's Intranet
<b>Will my application run?</b>	Focus on common middleware for initial migrations, communicating results to application teams
<b>Will this impact my business priorities?</b>	Migration process leverages planned changes and takes other business priorities into consideration
<b>What about technical training?</b>	Training to be delivered to application owners and development teams





IBM System z

## Additional information about Linux on System z



**The Future Runs on System z**

IBM Systems

# Linux on System z and z/VM Web sites

<http://ibm.com/systems/z/linux>

<http://ibm.com/vm>

The image displays two screenshots of IBM web pages. The left screenshot is the 'Linux on IBM System z' page, featuring a sidebar with navigation links like 'About Linux on IBM System z', 'Solutions', and 'Software'. The main content area includes a heading 'Linux on IBM System z™' and a sub-heading 'An ideal foundation for on demand operating environments'. The right screenshot is the 'z/VM' page, showing a sidebar with links such as 'News', 'About z/VM', and 'Products and features'. The main content area features the heading 'z/VM® the newest VM hypervisor based on 64-bit z/Architecture.' and a table of supported releases.

Release	Status
z/VM V5.4	Announced
z/VM V5.3	Available
z/VM V5.2	Also supported



# Linux on System z at developerWorks

<http://ibm.com/developerworks/linux/linux390>

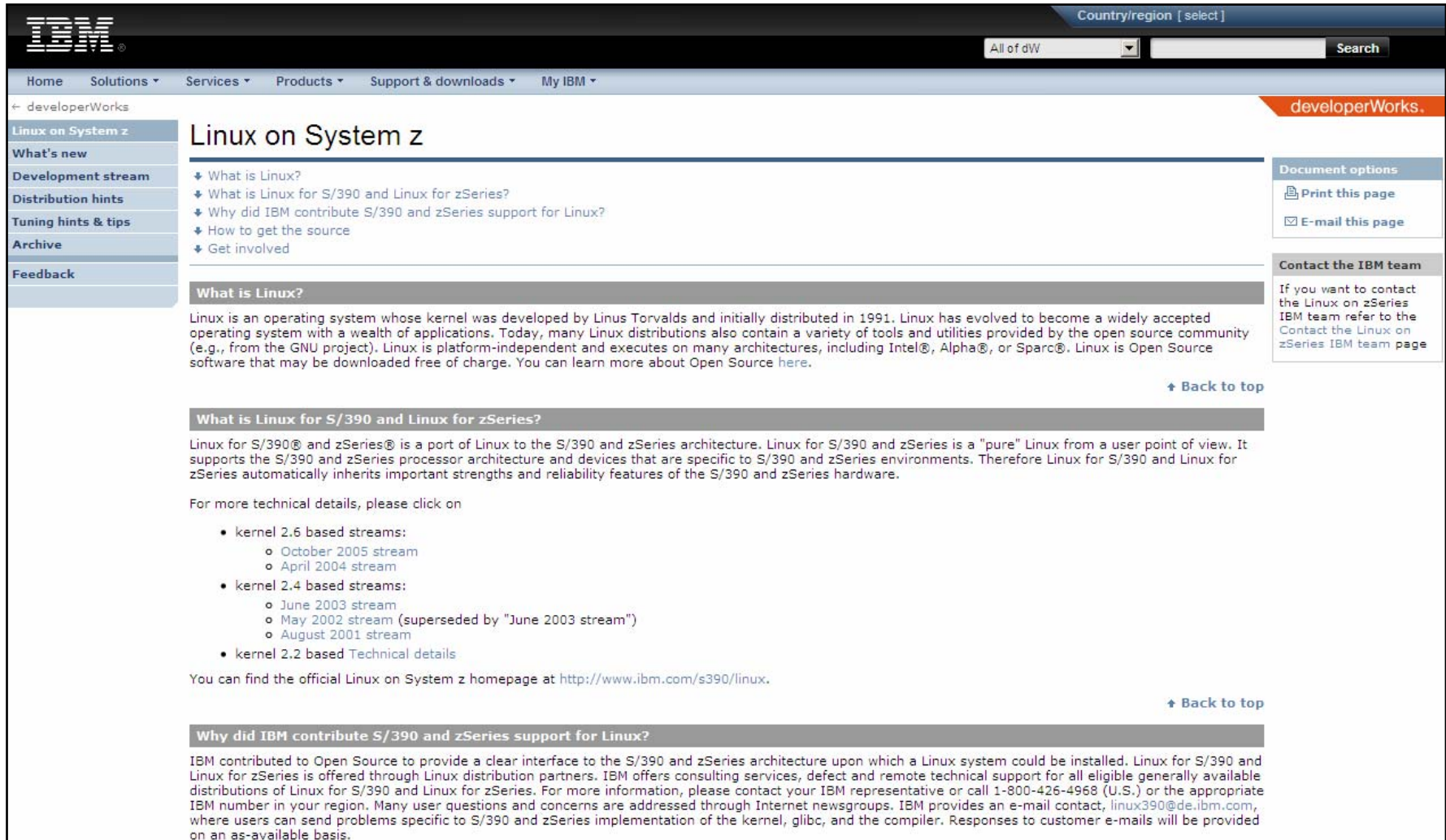

Country/region [ select ]  
All of dW Search

Home Solutions Services Products Support & downloads My IBM

← developerWorks **developerWorks.**

## Linux on System z

- What's new
- Development stream
- Distribution hints
- Tuning hints & tips
- Archive
- Feedback

↓ What is Linux?  
 ↓ What is Linux for S/390 and Linux for zSeries?  
 ↓ Why did IBM contribute S/390 and zSeries support for Linux?  
 ↓ How to get the source  
 ↓ Get involved

### What is Linux?

Linux is an operating system whose kernel was developed by Linus Torvalds and initially distributed in 1991. Linux has evolved to become a widely accepted operating system with a wealth of applications. Today, many Linux distributions also contain a variety of tools and utilities provided by the open source community (e.g., from the GNU project). Linux is platform-independent and executes on many architectures, including Intel®, Alpha®, or Sparc®. Linux is Open Source software that may be downloaded free of charge. You can learn more about Open Source [here](#).

↑ Back to top

### What is Linux for S/390 and Linux for zSeries?

Linux for S/390® and zSeries® is a port of Linux to the S/390 and zSeries architecture. Linux for S/390 and zSeries is a "pure" Linux from a user point of view. It supports the S/390 and zSeries processor architecture and devices that are specific to S/390 and zSeries environments. Therefore Linux for S/390 and Linux for zSeries automatically inherits important strengths and reliability features of the S/390 and zSeries hardware.

For more technical details, please click on

- kernel 2.6 based streams:
  - October 2005 stream
  - April 2004 stream
- kernel 2.4 based streams:
  - June 2003 stream
  - May 2002 stream (superseded by "June 2003 stream")
  - August 2001 stream
- kernel 2.2 based Technical details

You can find the official Linux on System z homepage at <http://www.ibm.com/s390/linux>.

↑ Back to top

### Why did IBM contribute S/390 and zSeries support for Linux?

IBM contributed to Open Source to provide a clear interface to the S/390 and zSeries architecture upon which a Linux system could be installed. Linux for S/390 and Linux for zSeries is offered through Linux distribution partners. IBM offers consulting services, defect and remote technical support for all eligible generally available distributions of Linux for S/390 and Linux for zSeries. For more information, please contact your IBM representative or call 1-800-426-4968 (U.S.) or the appropriate IBM number in your region. Many user questions and concerns are addressed through Internet newsgroups. IBM provides an e-mail contact, [linux390@de.ibm.com](mailto:linux390@de.ibm.com), where users can send problems specific to S/390 and zSeries implementation of the kernel, glibc, and the compiler. Responses to customer e-mails will be provided on an as-available basis.

## Internet list server discussions

### ■ IBMVM discusses z/VM

- To subscribe, send a note to [listserv@listserv.uark.edu](mailto:listserv@listserv.uark.edu). In the body of the note, write only the following line:
  - **SUBSCRIBE IBMVM** *firstname lastname*
- View and search the current list and archives:
  - <http://listserv.uark.edu/archives/ibmvm.html>

### ■ LINUX-390 discusses Linux on System z

- To subscribe, send a note to [listserv@vm.marist.edu](mailto:listserv@vm.marist.edu). In the body of the note, write only the following line:
  - **SUBSCRIBE LINUX-390** *firstname lastname*
- View and search the current list and archives:
  - <http://www.marist.edu/htbin/wlvindex?linux-390>

## Additional web sites

- **z/VM resources for Linux on IBM System z**
  - <http://ibm.com/vm/linux>
- **Wikipedia**
  - [http://wikipedia.org/wiki/Linux\\_on\\_zSeries](http://wikipedia.org/wiki/Linux_on_zSeries)
- **General z/VM tuning tips**
  - <http://ibm.com/vm/perf/tips>

## Thank you

### **Jim Elliott**

Consulting Sales Specialist – System z New Workloads

IBM Canada Ltd.

[jim\\_elliott@ca.ibm.com](mailto:jim_elliott@ca.ibm.com)

905-316-5813

<http://ibm.com/linux>

<http://ibm.com/systems/z>

<http://ibm.com/vm/devpages/jelliott>



## Notices

© Copyright IBM Corporation 2000, 2008. All rights reserved.

This document contains words and/or phrases that are trademarks or registered trademarks of the International Business Machines Corporation in the United States and/or other countries. For information on IBM trademarks go to <http://www.ibm.com/legal/copytrade.shtml>.

The following are trademarks or registered trademarks of other companies.

Java and all Java-related trademarks and logos are trademarks of Sun Microsystems, Inc., in the United States and other countries.

UNIX is a registered trademark of The Open Group in the United States and other countries.

Microsoft, Windows and Windows NT are registered trademarks of Microsoft Corporation.

Red Hat, the Red Hat "Shadow Man" logo, and all Red Hat-based trademarks and logos are trademarks or registered trademarks of Red Hat, Inc., in the United States and other countries.

Linux is a trademark of Linus Torvalds in the United States, other countries, or both.

All other products may be trademarks or registered trademarks of their respective companies.

### Notes:

This publication was produced in Canada. IBM may not offer the products, services or features discussed in this document in other countries, and the information may be subject to change without notice. Consult your local IBM business contact for information on the product or services available in your area.

All statements regarding IBM's future direction and intent are subject to change or withdrawal without notice, and represent goals and objectives only.

Information about non-IBM products is obtained from the manufacturers of those products or their published announcements. IBM has not tested those products and cannot confirm the performance, compatibility, or any other claims related to non-IBM products. Questions on the capabilities of non-IBM products should be addressed to the suppliers of those products.

Prices subject to change without notice. Contact your IBM representative or Business Partner for the most current pricing in your geography.

**Permission is hereby granted to SHARE to publish an exact copy of this paper in the SHARE proceedings. IBM retains the title to the copyright in this paper as well as title to the copyright in all underlying works. IBM retains the right to make derivative works and to republish and distribute this paper to whomever it chooses in any way it chooses.**