

**SHARE**

Technology • Connections • Results

# Tending the SANity of the Flock

## SAN Experiences at Nationwide

Rick Troth <trothr@nationwide.com>

February 25, 2008

SHARE 110 session 9286



# Disclaimer

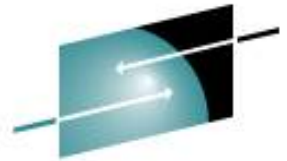

**S H A R E**  
Technology • Connections • Results

The content of this presentation is informational only and is not intended to be an endorsement by Nationwide Insurance. Each site is responsible for their own use of the concepts and examples presented.

Or in other words: Your mileage may vary. “It Depends.” Results not typical. Actual mileage will probably be less. Use only as directed. Do not fold, spindle, or mutilate. Not to be taken on an empty stomach.

When in doubt, ask! Still in doubt? test it!

# A New Iceberg

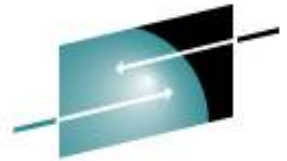

**SHARE**  
Technology • Connections • Results

- The issue: ECKD constrained
- The solution: put some content on SAN
- The implementation
- The results ...
- Lessons Learned
- Changes in z/VM 5.3

# Linux has Grown Fast!!



*And I thought we were busy **before** we got Linux!*

Rick Barlow, Aug 1, 2006

### zLinux Servers

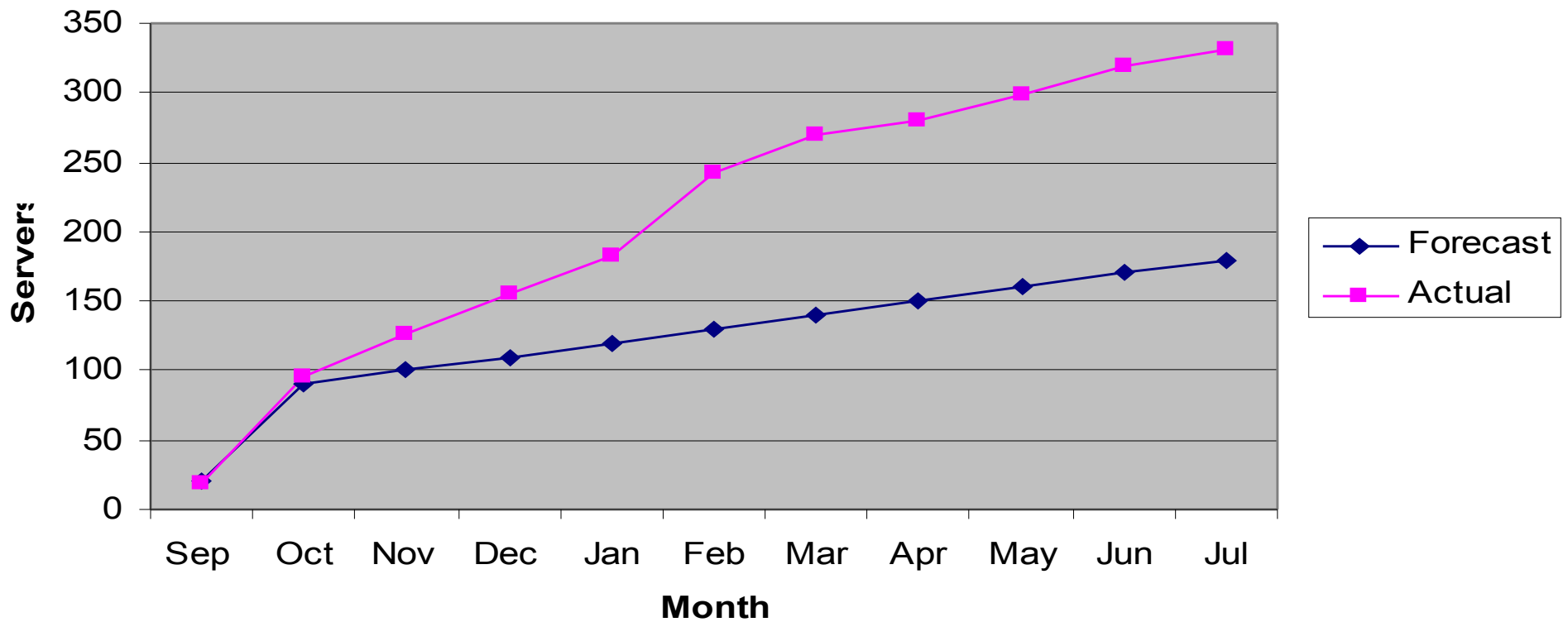

## Using up our ECKD Space

---

ECKD is constrained

- Cost (we could buy more, but ...)
- Interconnection / Interoperability
- Different Granularity (than other Linux)

So ... put “user files” onto SAN

# Stretching the Shared Disk Envelope



- Can we share SAN volumes? simultaneously? across unlike systems?
- Will discuss shared filesystems more, and especially read-only root, later in the week (session 9216)

# Storage Area Network



- common disk hardware interface for all large systems, not just IBM System z
- opportunity to share disk-resident content across platforms
- common skills and work for storage management staff
- potential for more cost effective data storage options (but why?)

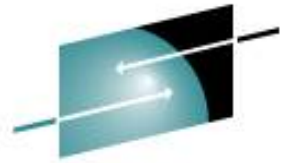

**S H A R E**

Technology • Connections • Results

# Basic Storage Requirements

---

- Replication (more than failover)
- Multipath (failover within storage space)
- Backup (multiple points of recovery)
- Security / Isolation



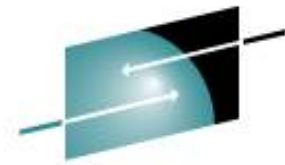

# z9 processor

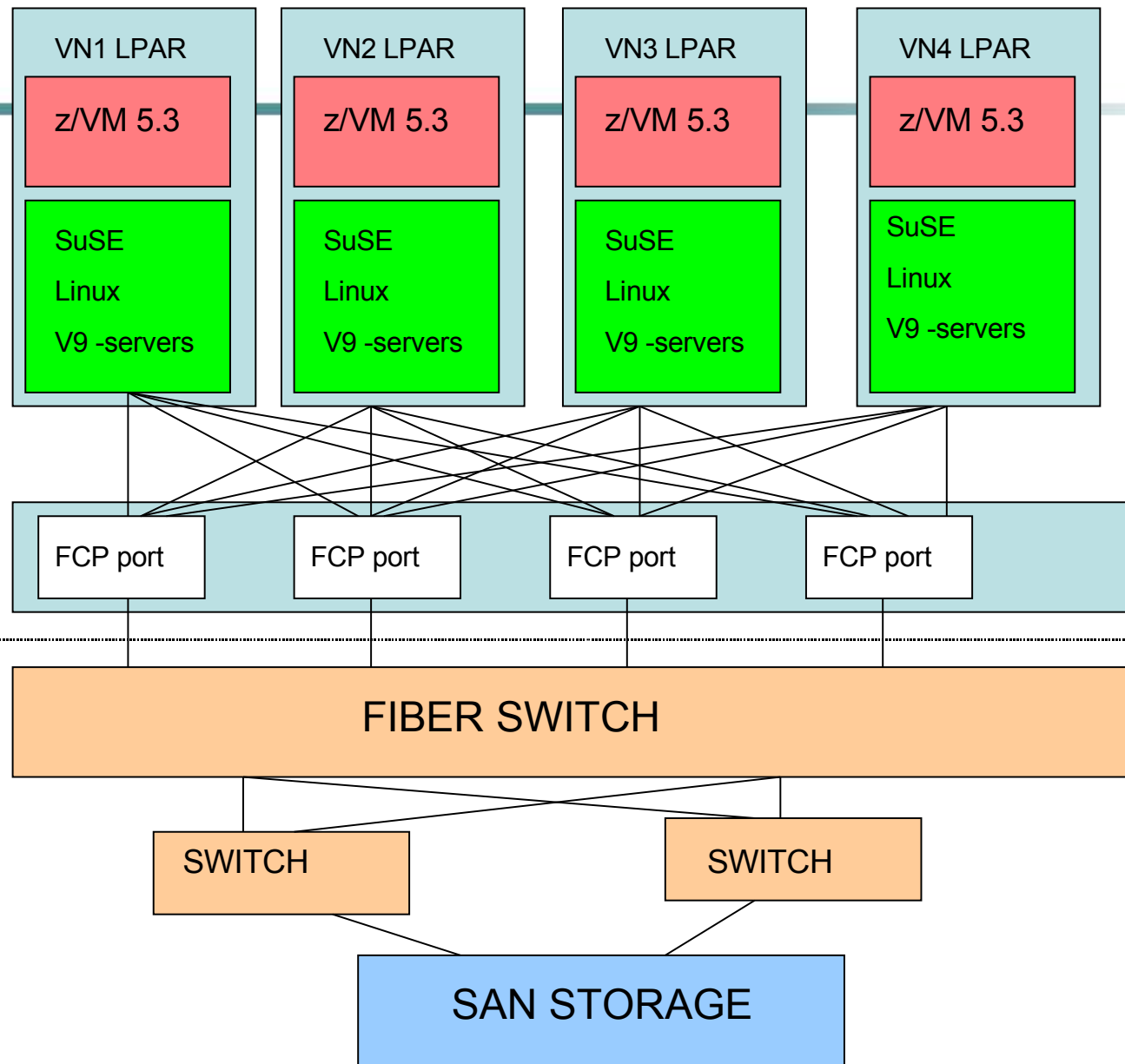

# Storage Area Network

---



## What SAN is not ...

- SAN is not NAS (Net Attached Storage)
- SAN is not a networked filesystem
  - Not Unix NFS protocol
- SAN is not “mapped drives”
  - Not Windows SMB protocol (not CIFS)

# Storage Area Network

---



What SAN is ...

- External Storage with Long Wires
- Talks like SCSI Disk
- Works like Mainframe Disk (sort of)
- Physically isolated from other networks

# Storage Area Network

---

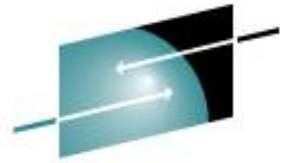

**S H A R E**

Technology • Connections • Results

## Picking out Furniture ...

- Point to Point
- Arbitrated Loop
- Switched Fabric ←

# ECKD mainframe disk

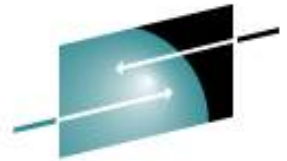

**SHARE**  
Technology • Connections • Results

- **z/VM (CP)**
- **z/VM (CMS)**
- **Linux**
- **VSE**
- **z/OS**

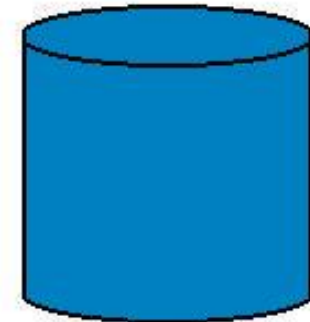

ECKD

extended count/key/data  
(and tracks & records)

ECKD traffic includes non-data

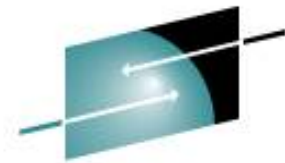

**S H A R E**

Technology • Connections • Results

# FBA mainframe disk

- **z/VM (CP)**
- **z/VM (CMS)**
- **Linux**
- **VSE**
- **z/OS**

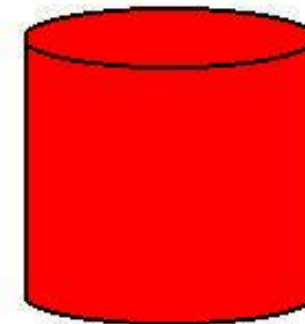

FBA

fixed blocks / just data

z/OS cannot use FBA disks

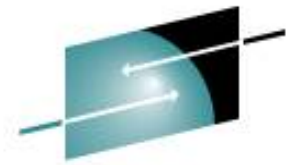

## SAN disk or SCSI disk

- z/VM (CP)
- z/VM (CMS, via EDEV)
- Linux
- VSE
- **Solaris, AIX, HP-UX**
- **Windows**

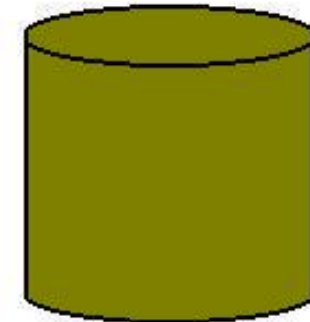

SAN

fixed blocks / just data

SAN disk presented as SCSI

## SAN is FBA ... sort of

- z/VM (CP)
- z/VM (CMS)
- Linux
- VSE

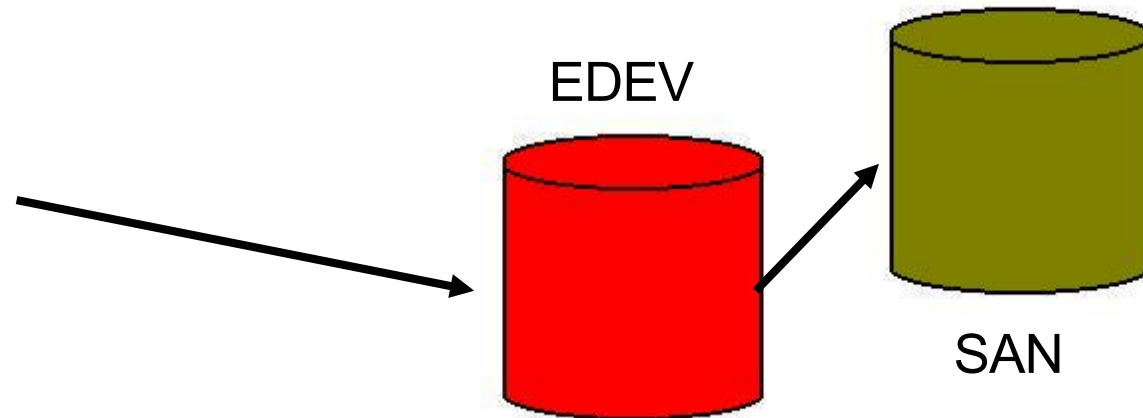

EDEV makes SAN look like FBA (9336)  
Same format. Same I/O command codes.



## “The Nucleus Got Bigger”

---

- 31-bit support dropped, CP Nucleus should have gotten smaller
- SAN support (EDEV) added, CP Nucleus actually got *larger*

IBM leveraged AIX driver code – cool!

# FCP attached to VM

```
/* make a SAN volume work like an FBA disk */
'CP SET EDEV FF02 TYPE FBA ATTR SCSI' ,
  'FCP_DEV 010A WWPN 50060482D52CC7F2 LUN 0002000000000000' ,
  'FCP_DEV 020A WWPN 50060482D52CC7FD LUN 0002000000000000'
'CP VARY ON FF02'

/* how does it look to CP? */
'CP Q DASD DETAILS FF02'
'CP Q 10A 20A'
...
FF02  CUTYPE = 6310-80, DEVTYPE = 9336-10, VOLSER = SAN002,
      CYLS = 91003, BLKS = 70709760
FCP  010A ATTACHED TO SYSTEM    0000 CHPID 50
FCP  020A ATTACHED TO SYSTEM    0000 CHPID 54
```

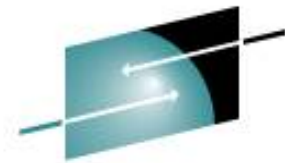

**S H A R E**

Technology • Connections • Results

## FCP attached to guest

---

- Requires Multipath Support in Linux
  - Two or more FCP “channels” per guest
- Demands Multipath Management
- Some Loss of Control (over guest storage)
- Coarse Grained Allocations
  - Probably okay if you use LVM
- Should it be N-port Virtualized?

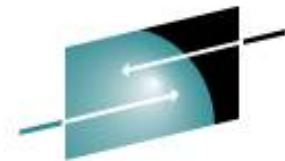

**S H A R E**

Technology • Connections • Results

# FCP attached to guest – Two HBAs

```
FCP 0100 ON FCP 0304 CHPID D1 SUBCHANNEL = 0018
0100 DEVTYPE FCP CHPID D1 FCP
0100 QDIO ACTIVE QIOASSIST ACTIVE
```

...

```
WWPN C05076FC7D000D90
```

```
FCP 0200 ON FCP 0404 CHPID D5 SUBCHANNEL = 0019
0200 DEVTYPE FCP CHPID D5 FCP
0200 QDIO ACTIVE QIOASSIST ACTIVE
```

...

```
WWPN C05076FC7D001110
```

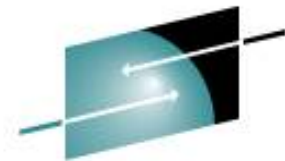

**S H A R E**

Technology • Connections • Results

## FCP attached to guest

---

```
cd /sys/bus/ccw/drivers/zfcp
echo 1 > $HBA/online
echo $WWPN > $HBA/port_add
echo $LUN > $HBA/$WWPN/unit_add

ls -l $HBA/$WWPN/$LUN/.
```

SAN speak: HBA == FCP adapter

# Storage Network – Multipath and LVM



## Picking out Appliances ...

- EVMS
- MPIO+LVM2 ←

LVM applies to direct FCP and to EDEV  
MPIO only needed for direct FCP

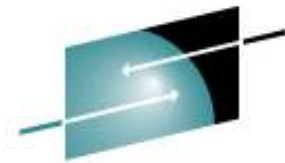

**S H A R E**

Technology • Connections • Results

## Can You Say “coalesce”?

- Combined 2+ Paths into One PV
  - <http://www.webster.com/dictionary/coalesce>
- “logical volume” in a different sense
  - Physical PV represents an I/O path
  - Logical PV is fed to LVM
- Modify `/etc/lvm/lvm.conf` accordingly

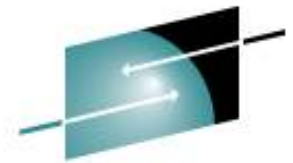

**S H A R E**

Technology • Connections • Results

## Can You Say “coalesce”?

- Modify `/etc/lvm/lvm.conf`:

```
filter = [ "r|^/dev/sd|",  
          "r|^/dev/dm|", ...
```



# Can You Say “coalesce”?

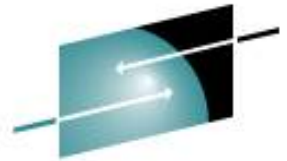

**S H A R E**  
Technology • Connections • Results

```
# cat /proc/partitions
```

```
...
```

```
8      0      35354880  sda
```

```
8      16     35354880  sdb
```

```
253    0      35354880  dm-0
```

```
8      32     35354880  sdc
```

```
8      48     35354880  sdd
```

```
253    1      35354880  dm-1
```

# FCP attached to Linux guest

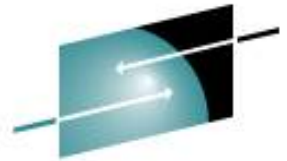

**S H A R E**

Technology • Connections • Results

Define paths manually or via YaST, then ...

```
/etc/init.d/boot.multipath start
/etc/init.d/multipathd start
pvcreate /dev/mapper/360060480000190100630533030453832
vgcreate sanvg1 \
    /dev/mapper/360060480000190100630533030453832
lvcreate -L 4G -n sanlv1 sanvg1
```

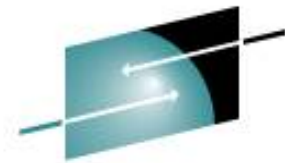

**S H A R E**

Technology - Connections - Results

## Avoid gratuitous partition tables

---

- Common partitioning: zero, 1, 2, or 3
- Understood by either driver (scsi or dasd)
- Use PC “primary partitions”

But don't!

- Partitioned requires double layer admin
- Non-partitioned gives simpler LVM admin
- Non-partitioned makes sharing easier

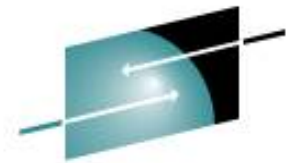

**S H A R E**

Technology • Connections • Results

## If you must partition ...

<i>disk type</i>	<i>driver</i>	<i>format with</i>	<i>partition with</i>
ECKD	dasd	dasdfmt	<b>fdasd</b>
FBA	dasd		<b>fdisk</b>
SAN	zfcpscsi		<b>fdisk</b>
EDEV	dasd		<b>fdisk</b>

# Multipath Management

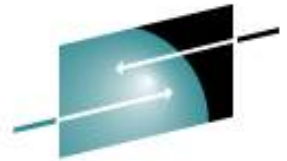

**S H A R E**

Technology - Connections - Results

```
:vmid.NZVJT002   :node.VS2
:chpid.51        :realwwpn.50050764016208c5
:rdev.0304       :virtwwpn.c05076fc7d800c10
:sanframe.1822   :sande.v.0EE0
:targwwpn.50060482d52e4fa3 :lun.002700000000000000
:size.36G        :uuid.360060480000190101822533030454530
```

# SAN is Seamless

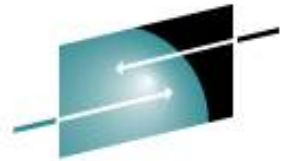

**S H A R E**

Technology • Connections • Results

- Operating systems stay on ECKD for now
- No Change of application file access
- Open-Ended storage capacity
- Secured at the hardware level

# Mixed Media Methodology

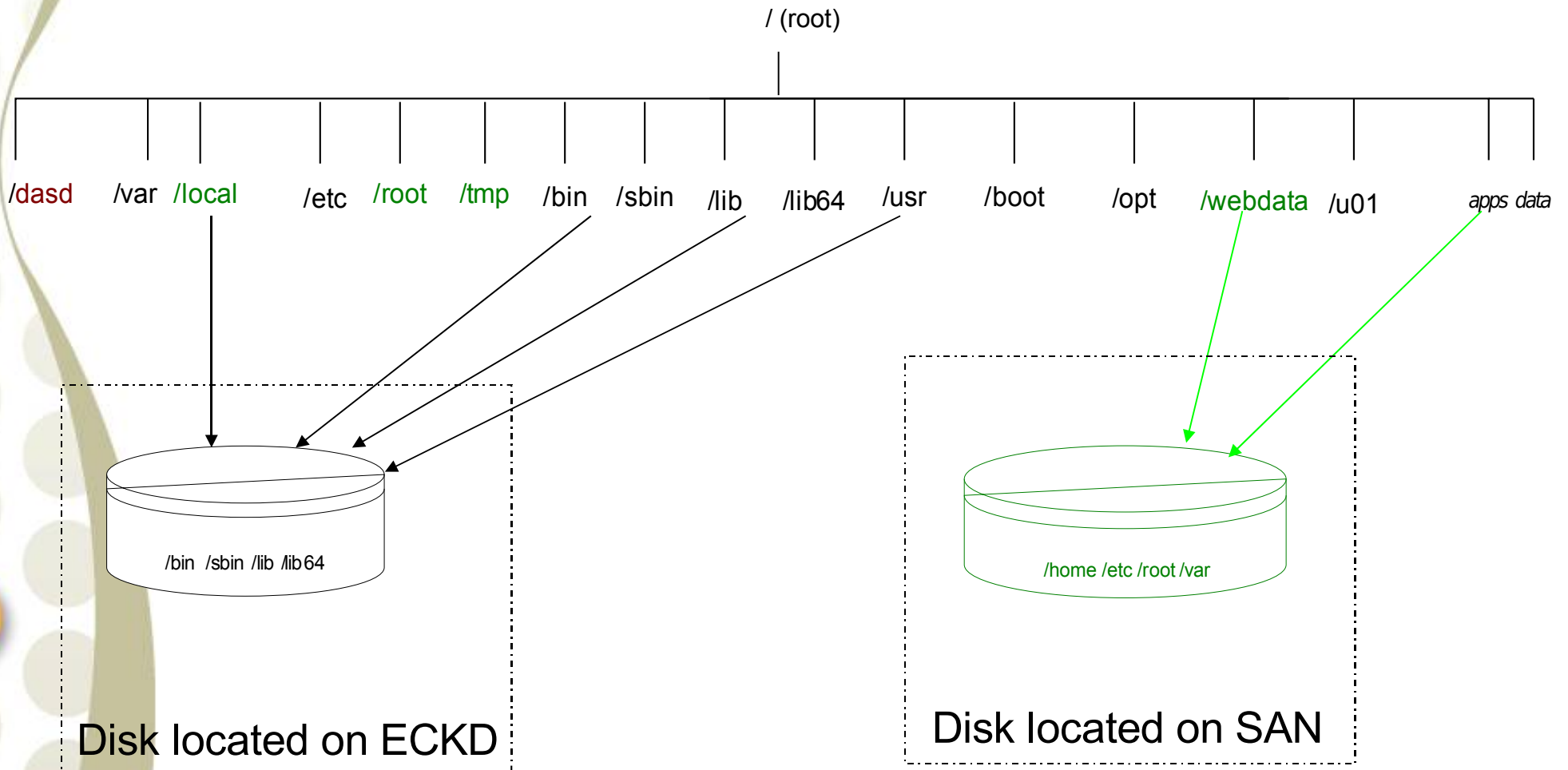
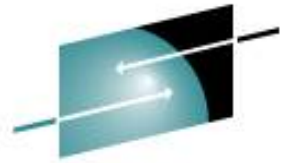

## Speaking of Security ...

---

- LUNs are zoned and masked
- NPIV enabled for the fabric
- Without NPIV
  - One (real) WWPN for CHPID
- With NPIV
  - Unique (virtual) WWPN per subchannel



## About EDEV ...

---

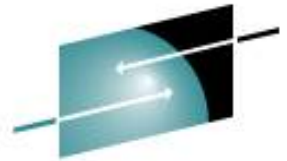

**S H A R E**

Technology • Connections • Results

- CP emulates FBA on SAN
- Device type 9336 (like 3370 or 3310)
- Attach EDEVs just like real DASD

# EDEV attached to VM

---

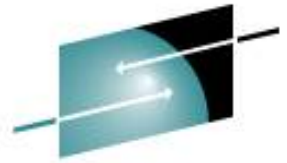

**S H A R E**

Technology • Connections • Results

- Minidisks
- Paging (and spooling)

## EDEV attached to guest

---

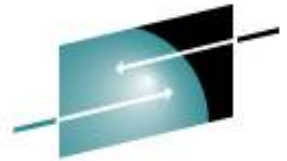

**S H A R E**

Technology • Connections • Results

- Attached to CMS to run CPFMTXA
- Attached to Linux for “full LUN”

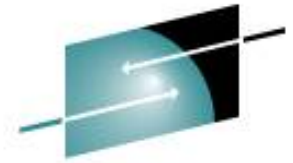

**S H A R E**

Technology • Connections • Results

## Reasons to not run EDEV

---

- Slower Throughput (protocol translation)
- Increased Overhead (hypervisor CPU)
- Multipath Failover (VM lags Linux)

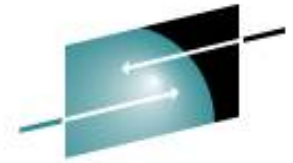

**S H A R E**

Technology • Connections • Results

## Reasons to run EDEV

---

- FBA simpler to configure in Linux
- No need to re-configure when cloning
- Minidisks and CP Dir to manage them
- Minidisk caching
- Can share minidisks (or full volume MD)
- ...

# Reasons to run EDEV

---

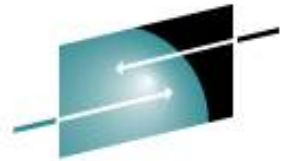

**S H A R E**  
Technology • Connections • Results

- ...
- No driver currency issues (in Linux)
- Easier sharing across LPARs
- EDEV easier to monitor than direct SAN

# Stretching the Brand X Envelope

---



- It's all about interoperability ...

SAN does for disk

what z/VM does for systems ... sort of

***Thank You!!***

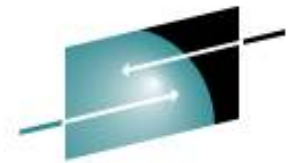

**S H A R E**

Technology • Connections • Results



**Richard Troth**  
Senior VM Systems Programmer

**Nationwide Services Co., LLC**

One Nationwide Plaza, MB-02-201

Columbus, OH 43215-2220

Voice: 1-614-249-7642

Cell: 1-614-849-8255

[trothr@nationwide.com](mailto:trothr@nationwide.com)