



IBM System z

Linux on System z – A Strategic View



Jim Elliott
Consulting Sales Specialist – System z
Product Manager – System z Operating Systems
IBM Canada Ltd.

IBM Systems
Simplify your IT.

9202 – Linux on System z – A Strategic View

- **Datacenters planning to adopt Linux have a key architectural choice to make in designing large-scale implementations**
- **Is the best approach to running Linux scale-out with rack-optimized servers, to scale up with large SMP servers using virtualization facilities to run many images on a single server?**
- **For many users, Linux on IBM System z may be the optimal choice**
- **Jim will describe how Linux on System z, in combination with z/VM, will provide a robust Linux environment which integrates well with z/OS, z/TPF and z/VSE**

Agenda

- Linux on System z overview
- Linux on System z deployment criteria
- **IBM Transformation: Major IT Consolidation Initiative**
- Additional information about Linux on System z



Linux user presentations on Wednesday

All sessions on the 3rd floor, Ford A&B

Session	Speaker	Title
9215 1:30pm	Marcy Cortes – Wells Fargo	Penguins Board the Stagecoach for the Linux Frontier: A User Experience with Linux on zSeries
9230 3:00pm	Alain Leclerc – CSPQ and David Kreuter – VM Resources	How to Rise Above the Challenges of Deploying z/VM and Linux on the Mainframe and Thrive
9231 4:30pm	Alain Leclerc – CSPQ and David Kreuter – VM Resources	Building a Strong z/VM and Linux Architecture on the Mainframe

Linux user presentations on Thursday

All sessions on the 3rd floor, Ford A&B

Session	Speaker	Title
9240 1:30pm	Erich Amrehn – IBM	Putting Linux on System z into Production: True Stories
9212 3:00pm	Jim Vincent – Nationwide	Linux for System z at Nationwide – From Woe to Whoa! How did We Get Here, Toto?
9213 4:30pm	Rick Barlow – Nationwide	Anatomy of a z Penguin – A Customer Experience Helping A Colony Thrive Under Extreme Conditions



IBM System z

Linux on System z overview



IBM Systems
Simplify your IT.

Take back control of your IT infrastructure

A data center in a box – not a server farm

- **Central point of management**
- **Increased resource utilization**
- **Potentially lower cost of operations**
 - Less servers
 - Fewer software licenses
 - Fewer resources to manage
 - Less energy, cooling and space
- **Fewer intrusion points**
 - Tighter security
- **Fewer points of failure**
 - Greater availability

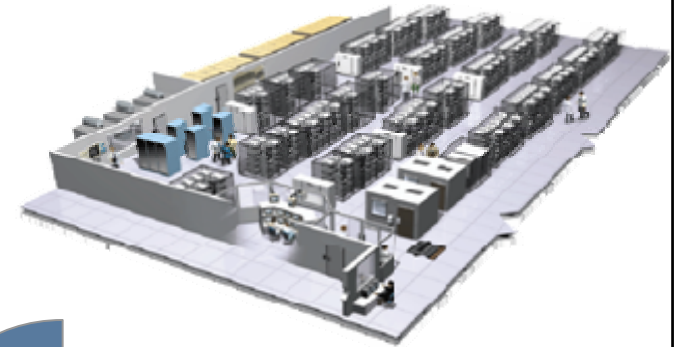

Linux on IBM System z

Linux + Virtualization + System z = SYNERGY

- **The legendary IBM mainframe – IBM System z**
 - Legendary dependability
 - Extremely security-rich, highly scalable
 - Designed for multiple diverse workloads executing concurrently
 - Proven high volume data acquisition and management
- **The IBM mainframe virtualization capabilities – z/VM 5.3**
 - Support for large real memory and 32 processors
 - Enhanced security and LDAP server/client
 - Enhanced memory management for Linux guests
 - Enhanced management functions for Linux
- **Open standards operating system – Linux for System z**
 - Reliable, stable, security-rich
 - Available from multiple distributors
 - Plentiful availability of skills administrators and developers
 - Large selection of applications middleware and tooling from IBM, ISVs and Open Source

What is Linux on System z?

- **A native mainframe operating environment**
 - Exploits IBM System z hardware
 - Not a unique version of Linux
- **Application sourcing strategy**
 - The IBM commitment to z/OS, z/VSE and z/TPF is not affected by this Linux strategy
 - Customers are offered additional opportunities to leverage their investments through Linux
 - New doors are opening for customers to bring Linux-centric workloads to the platform

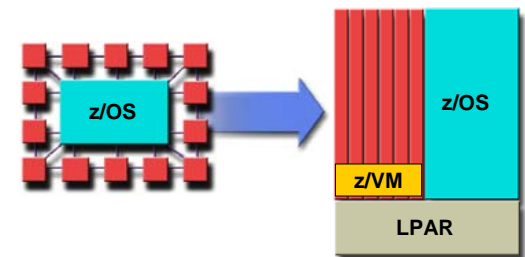
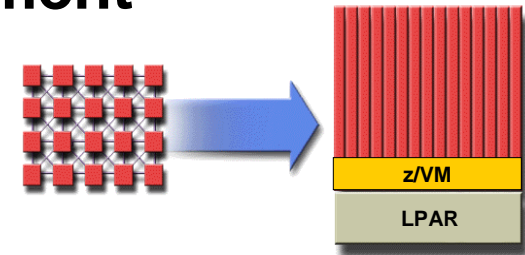

What System z brings to Linux

- **The most reliable hardware platform available**
 - Redundant processors and memory
 - Error detection and correction
 - Remote Support Facility (RSF)
- **Centralized Linux systems are easier to manage**
- **Designed to support mixed work loads**
 - Allows consolidation while maintaining one server per application
 - Complete work load isolation
 - High speed inter-server connectivity
- **Scalability**
 - System z9 EC scales to 54 application processors
 - System z9 BC scales to 7 application processors
 - Up to 8 dedicated I/O processors
 - Hundreds of Linux virtual servers

What is different about Linux on System z?

- **Access to System z specific hardware**
 - Crypto support – CPACF, Crypto2
 - Traditional and Open I/O subsystems
 - Disk (ECKD or SCSI) and tape
 - SAN Volume Controller
 - OSA-Express and OSA-Express2 for very high speed communication between z/OS and Linux
 - HiperSockets for ultra-high speed communication between z/OS and Linux on the same machine
- **z/VM aware**
 - Enhanced performance
 - System management tools

Value of Linux on System z

- **Reduced Total Cost of Ownership (TCO)**
 - Environmental savings – single footprint vs. hundreds of servers
 - Consolidation savings – less storage, less servers, less software licenses, less server management/support
- **Improved service level**
 - Systems management (single point of control)
 - Reliability, availability, security of System z
 - High performance integration with z/OS, z/VSE, z/TPF
- **Speed to market**
 - Capacity-on-demand capability on System z
 - Dynamic allocation of on-line users, less than 10 seconds to add a new Linux server image using z/VM and IBM DS8000

System z – The ultimate virtualization resource

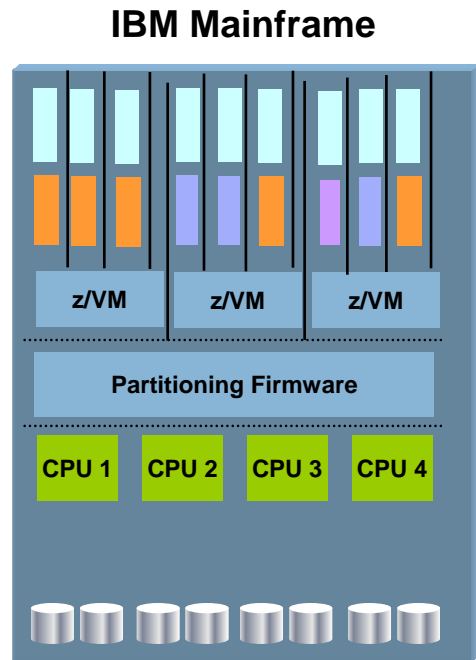

- **Utilization often exceeds 90%**
 - Handles peak workload utilization of 100% without service level degradation
- **Massive consolidation platform**
 - Up to 60 logical partitions, 100s to 1000s of virtual servers under z/VM
 - Virtualization is built-in, not added-on
 - HiperSockets for memory-speed communication
 - Most sophisticated and complete hypervisor function available
- **Intelligent and autonomic management of diverse workloads and system resources based on business policies and workload performance objectives**

z/VM – Unlimited virtualization

- **z/VM provides a highly flexible test and production environment for enterprises deploying the latest e-business solutions**
- **z/VM helps enterprises meet their growing demands for multi-system server solutions with a broad range of support for operating system environments**
- **Mature technology – VM/370 introduced in 1972**
- **Software Hypervisor integrated in hardware**
 - Sharing of CPU, memory and I/O resources
 - Virtual network – virtual switches/routers
 - Virtual I/O (mini-disks, virtual cache, ...)
 - Virtual appliances (SNA/NCP, etc.)
- **Easy management**
 - Rapid install of new servers – cloning or IBM Director task z/VM Center
 - Self-optimizing workload management

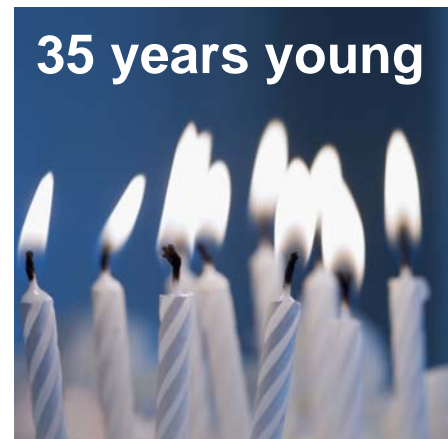

The value of z/VM for Linux

- **Enhanced performance, growth and scalability**
 - Server consolidation enables horizontal growth
 - N-tier architecture on two tiers of hardware
 - Extensive support for sharing resources
 - Virtual networking
 - Effective isolation of Linux images, if required
- **Increased productivity**
 - Development and testing
 - Production support
- **Improved operations**
 - Backup and recovery
 - Command and control

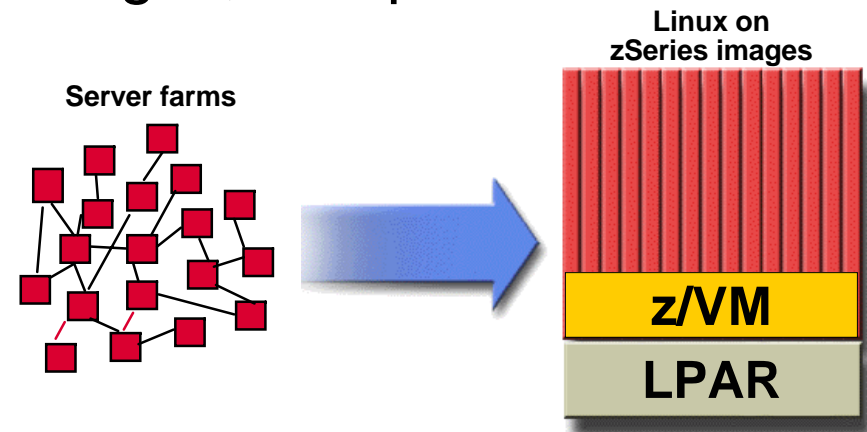

Integrated Facility for Linux

- **Additional engines dedicated to Linux workloads**
 - Supports z/VM and Linux on System z
 - IFLs on “sub-uni” systems run at “full speed”
 - z800, z890, **z9 EC**, **z9 BC**
- **Traditional mainframe software charges unaffected**
 - IBM mainframe software
 - Independent Software Vendor products
- **Linux and z/VM charged only against the IFLs**

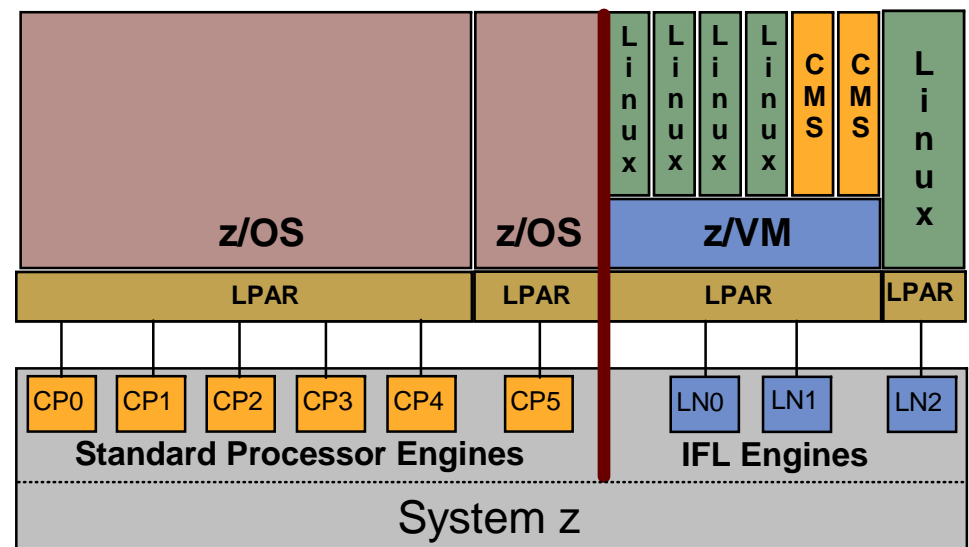

Application serving with Linux on System z

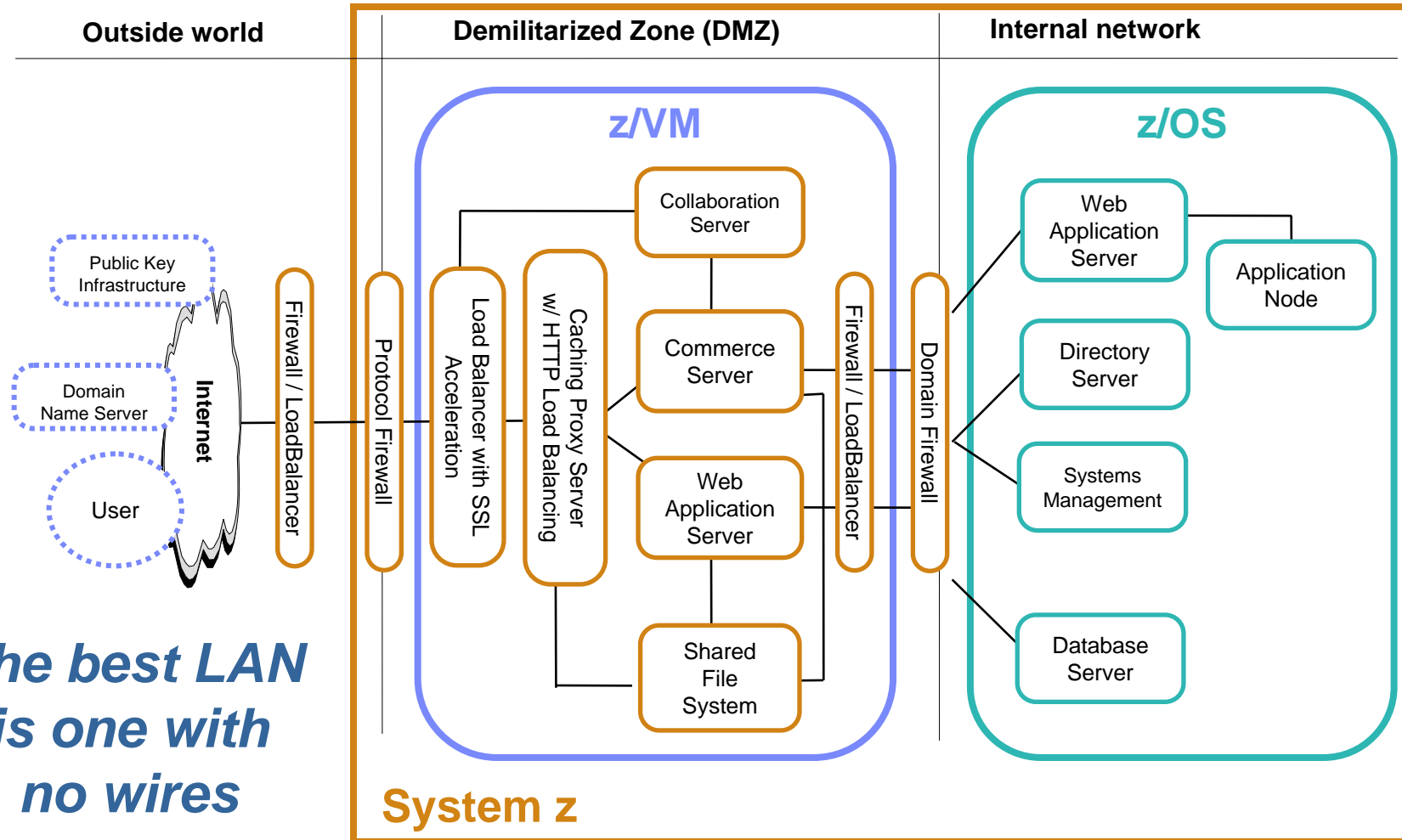

*The best LAN
is one with
no wires*

System z



IBM System z

Linux on System z deployment criteria



IBM Systems
Simplify your IT.

Infrastructure simplification

- Customers leveraging scale up and scale out technologies to simplify and integrate their on demand operating environment
- As one solution option:
 - Large SMP and Rack Optimized servers integrated with Linux, Java and Grid technologies can enable this transformation

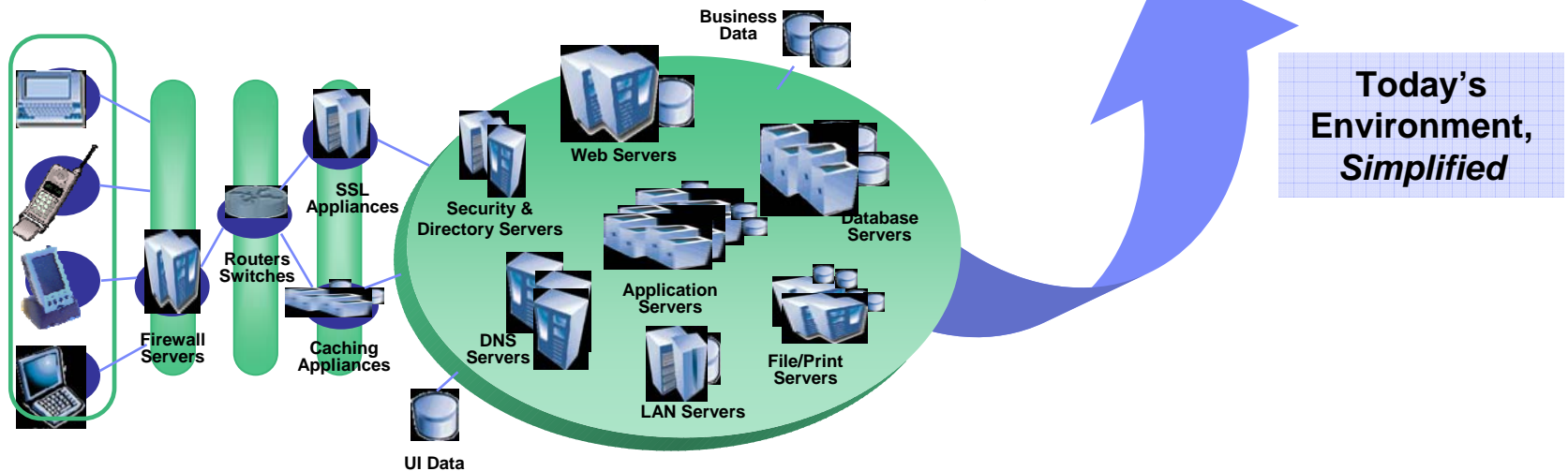
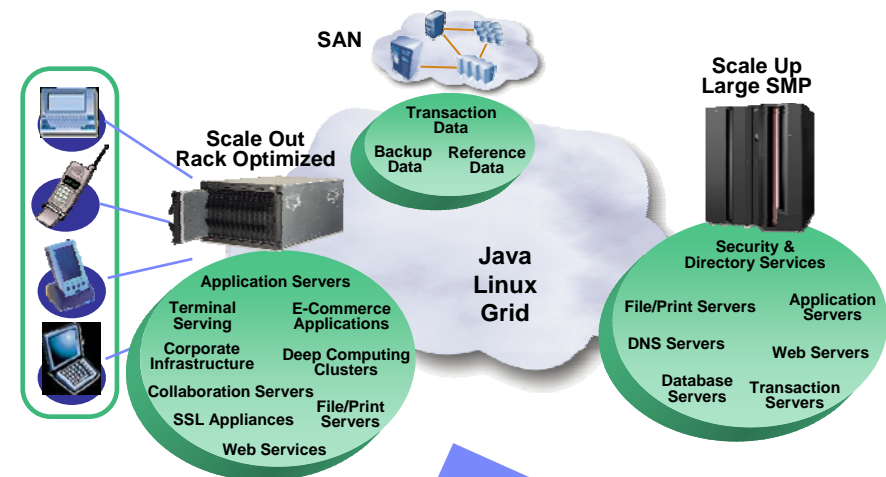

Ideal blade implementations

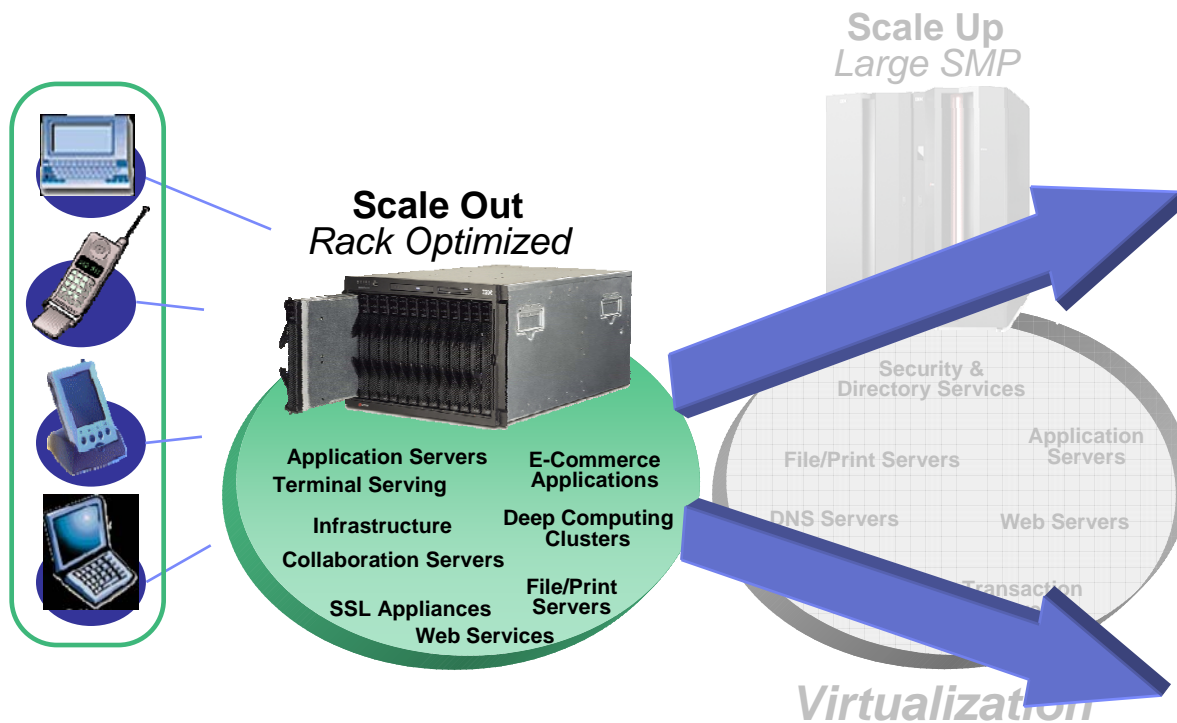

- **Clustered workloads**
- **Distributed computing applications**
- **Infrastructure applications**
- **Small database**
- **Processor and memory intensive workloads**
- **Centralized storage solutions**

Ideal mainframe implementations

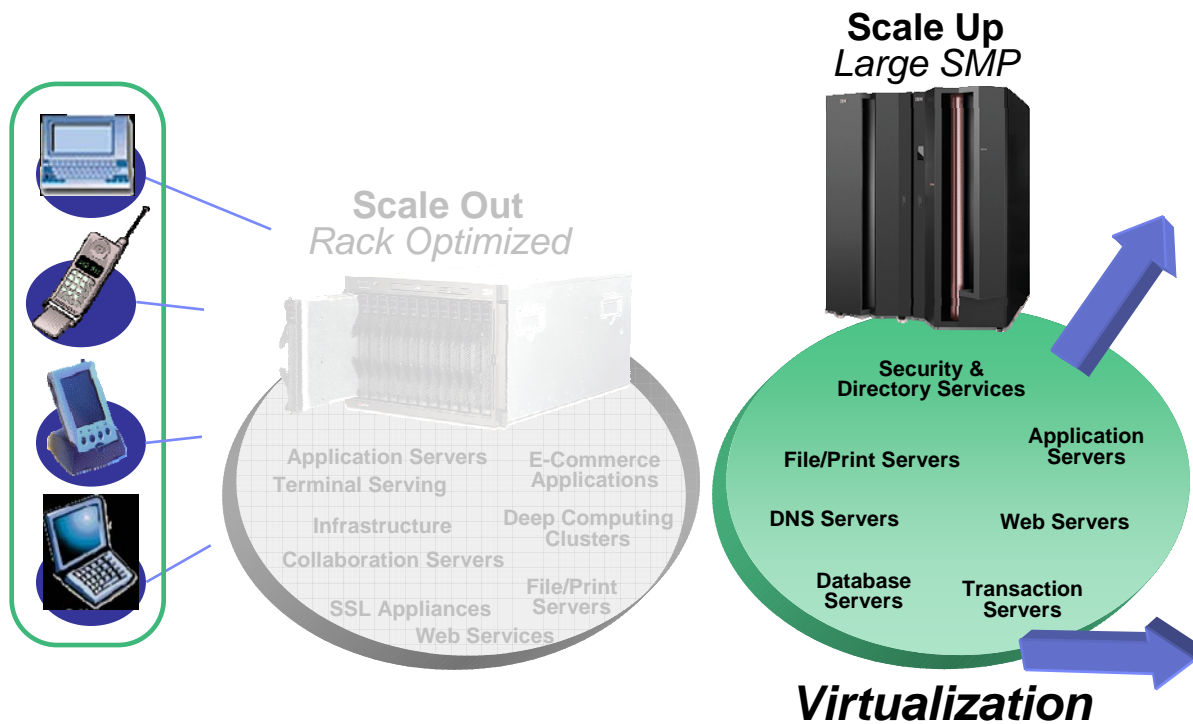

- High performance transaction processing
- I/O intensive workloads
- Large database serving
- High resiliency and security
- Unpredictable and highly variable workload spikes
- Low utilization infrastructure applications
- Rapid provisioning and re-provisioning

Selecting an application

- **Performance on System z CPUs is comparable to CPUs on other platforms of similar speed**
 - CPU speed is not the entire story – it's in the architecture!
 - Architecture designed for multiple or consolidated workloads
 - System z has definite advantage with applications that have mixed CPU and I/O
- **System z and z/VM provide excellent virtualization capabilities**
 - Look for applications that are on lower utilized servers
 - Development and Test are good choices to start
- **Good planning is essential**
- **IBM can**
 - Perform sizing estimates
 - Assist with planning and initial installation needs



Where to deploy on System z – z/OS or Linux?

Technical Considerations

Linux  z/OS

Quality of Service

Linux  z/OS

Speed of deployment

Linux  z/OS

Degree of portability

Other Considerations

- Application availability
- Workload Management function and granularity
- File sharing across a Sysplex
- Manageability and scaling characteristics
- Availability of skill

Where to deploy – System z or “distributed”

Technical Considerations

System z ← “distributed”
Quality of Service

System z ← “distributed”
Speed of deployment
Instances 2 - n

System z ← “distributed”
Data Intensity

System z → “distributed”
Compute Intensity

Other Considerations

- **Application availability**
 - Certification of solution on hardware/software platform
- **Workload Management**
- **Manageability and scaling characteristics**
 - Especially DB2 on z/OS
 - Proximity of data to application
 - The best network is an internal network!

Linux on System z ISV status

ibm.com/systems/z/solutions/isv/linuxproduct.html

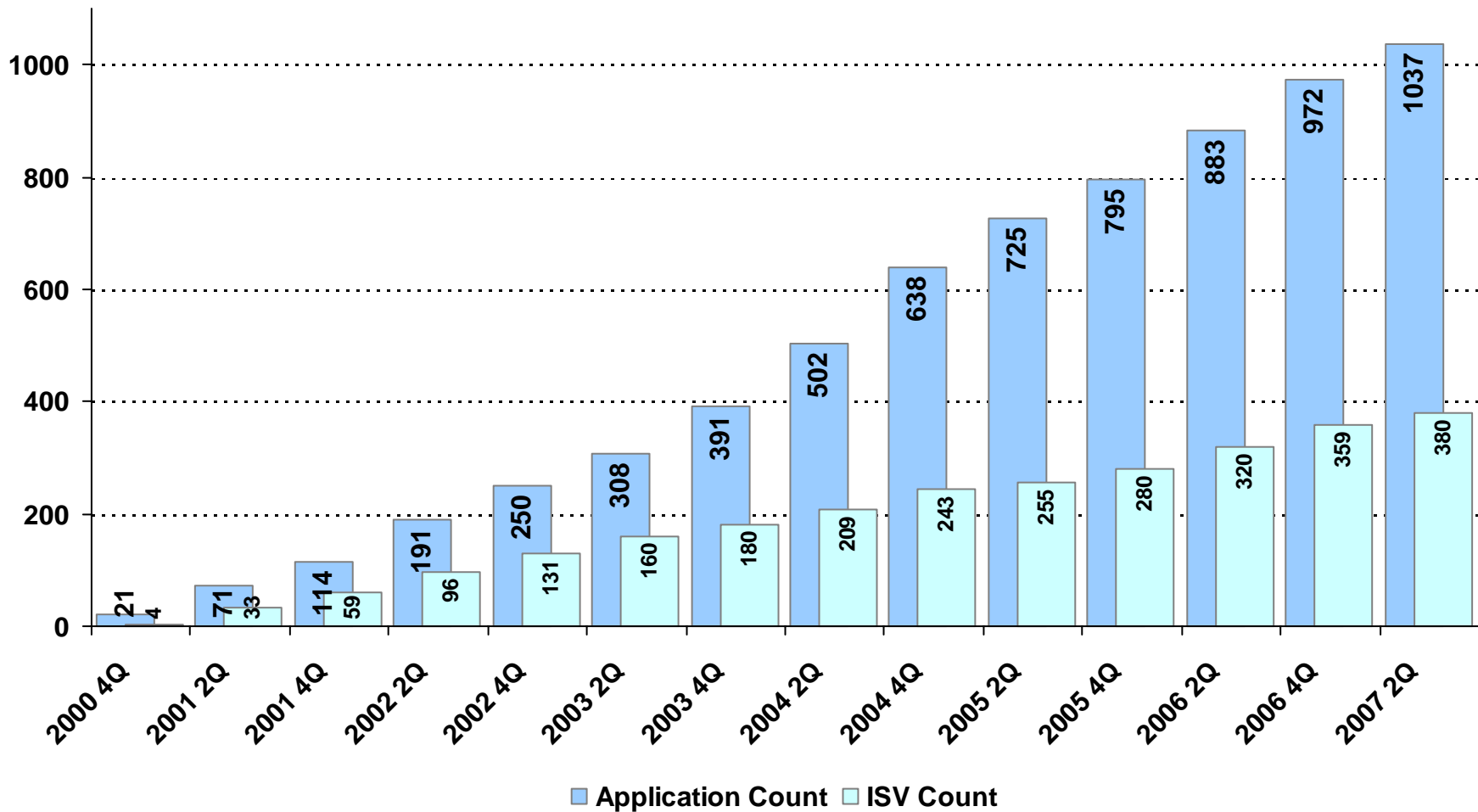

Workload share on utilized IFLs

Primary application

60%	Application serving for “legacy” systems e.g. WebSphere, SAP, CICS TG, DB2 Connect
30%	Data serving e.g. Oracle DB
5%	Workplace serving e.g. Domino, Scalix, other e-mail
5%	Infrastructure serving e.g. Apache, Samba, NFS, etc.
<1%	Linux application development/deployment

Notes: extrapolation based on analyzing 1/3 of inventory, excludes all IBM. February 2006

Linux on IBM System z

Take back control of your IT infrastructure

- **Unify the infrastructure**
 - IT optimization and server consolidation based on virtualization technology and Linux
 - Linux can help to simplify systems management with today's heterogeneous IT environment
- **Leverage the mainframe data serving strengths**
 - Deploy in less time, accessing core data on z/OS
 - Reduced networking complexity and improved security network “inside the box”
- **A secure and flexible business environment**
 - Linux open standards support for easier application integration
 - Unparalleled scale up / scale out capabilities
 - Virtual growth instead of physical expansion on x86 or RISC servers
- **Leverage strengths across the infrastructure**
 - Superior performance, simplified management, security-rich environment
 - High-performance security-rich processing with Crypto2 cryptographic co-processors
 - Backup and restore processes





IBM System z

IBM Transformation: Major IT Consolidation Initiative



IBM Systems
Simplify your IT.

IBM consolidation announcement highlights

- **IBM will consolidate thousands of servers onto approximately 30 System z mainframes**
- **We expect substantial savings in multiple dimensions: energy, software and system support costs**
- **Major proof point of IBM's 'Project Big Green' initiative**
- **The consolidated environment will use 80 percent less energy**
- **This transformation is enabled by the System z's sophisticated virtualization capability**

IBM's Project Big Green Spurs Global Shift To Linux On Mainframe

Plan to shrink 3,900 computer servers to about 30 mainframes targets 80 percent energy reduction over five years

Optimized environment to increase business flexibility

ARMONK, NY, August 1, 2007 – In one of the most significant transformations of its worldwide data centers in a generation, IBM (NYSE: IBM) today announced that it will consolidate about 3,900 computer servers onto about 30 System z mainframes running the Linux operating system. The company anticipates that the new server environment will consume approximately 80 percent less energy than the current set up and expects significant savings over five years in energy, software and system support costs.

At the same time, the transformation will make IBM's IT infrastructure more flexible to evolving business needs. The initiative is part of Project Big Green, a broad commitment that IBM announced in May to sharply reduce data center energy consumption for IBM and its clients.

IBM infrastructure

Continued server growth brought physical space challenges

■ Infrastructure Challenges

- Floor space challenges in Boulder and Southbury
- Underutilized assets maintaining outdated web infrastructure
- Additional physical space needed for future SO growth
- Continued infrastructure cost pressure

Distributed server consolidation is the next step in cost savings after the massive consolidation of IBM Data Centers

Application Distribution between Mainframe and Distributed Servers

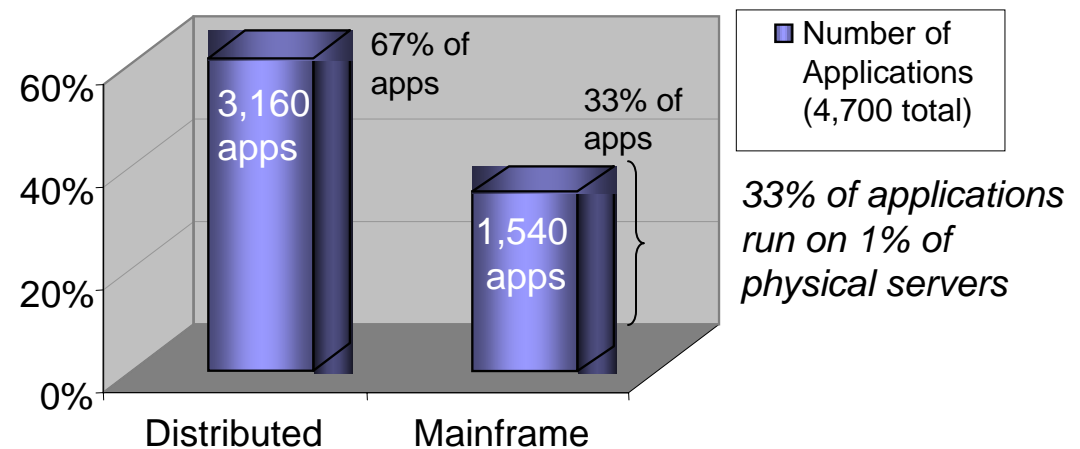

IBM distributed consolidation to System z

- **Performed TCO and consolidation assessment on IBM portfolio**
 - Cross-IBM effort: System z, Software Migration Services, TCO Academy, Migration Factory

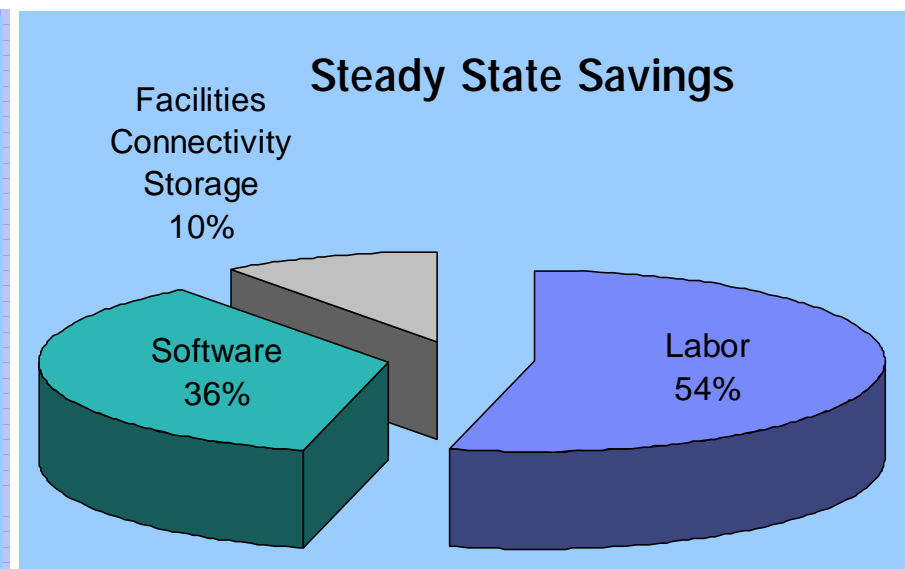
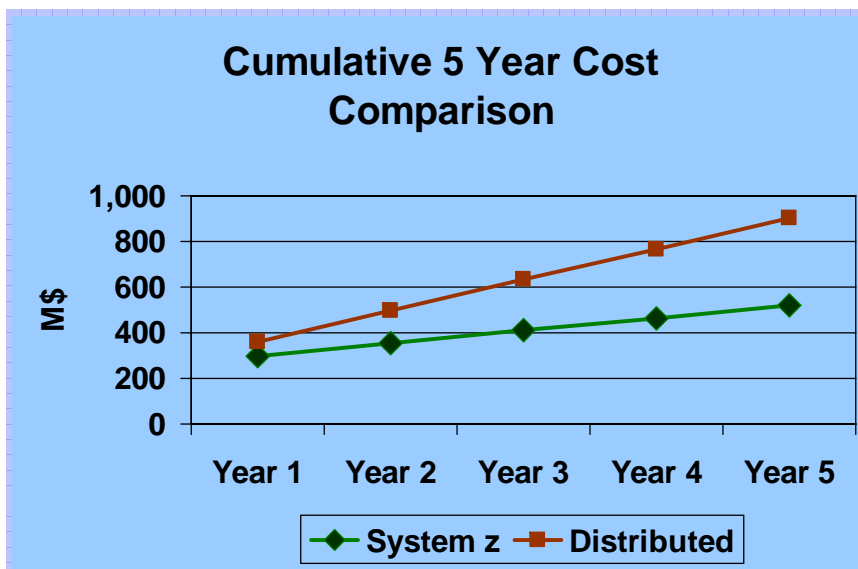

- **Identified substantial savings opportunity**
 - Annual Energy Usage reduced by 80%
 - Total floor space reduced by 85%
- **Cornerstone initiative in the IBM quality of service imperative**



Critical success factors

- **Sponsor needs to have an enterprise view**
 - Complete TCO identifies full benefit to the corporation
 - Broader than IT or TCA views
 - Sponsor assists in managing execution of corporate level plan
 - Versus application by application
- **Strategic investment will be required for migration**
 - Funding (may be out of cycle)
 - Training and System z resource deployment
- **Clear goals, dedicated team, inclusive leadership is needed to execute the migration**
 - Define the strategy for a holistic solution
 - Manage with an integrated, collaborative approach to help people overcome preconceived mindsets and become open to change
- **Leveraging talent and capability across all of IBM driving rapid results**
 - Integrating talent from Hardware group, Software group and Services while sharing information between the IBM Global Account, strategic outsourcing and commercial accounts demonstrated the value intrinsic in the IBM Corporation

Marketplace reaction

- ***“Charles King, an analyst with PundIT, said IBM not only reduces its own power and energy costs ... it also creates a showcase for its signature, high-end product – the System z mainframe – that will show its customers how they can also benefit from the technology”***
 - eWeek
- ***“Every now and then, an announcement makes me think the world is shifting ... from the dawn of personal computers to the dawn of Web, now we have that IBM will reduce 3900 servers to 30 mainframes ... this is another turning point for the industry...”***
 - Scott Mace podcast on IT Conversations
- ***“IBM on Wednesday said it has consolidated 3,900 computer servers in six locations worldwide onto about 30 refrigerator-sized mainframes running Linux, a move that the tech giant claims reduces computer devoted floor space by 85% and will cut costs by \$250 million.”***
 - InformationWeek
- ***“This is a bold move in terms of eating your own dog food.”***
 - Dan Olds: Search Data Center



IBM System z

Additional information about Linux on System z



IBM Systems
Simplify your IT.

Linux on System z and z/VM Web sites

ibm.com/systems/z/linux *ibm.com/vm*

Country/region [select] Search

Home Business solutions ▾ IT services ▾ Products ▾ Support & downloads ▾ My IBM ▾

Welcome Mr. Jim Elliott [Not you?] [IBM Sign in]

IBM Systems > System z > Operating systems >

Linux on IBM System z™

An ideal foundation for on demand operating environments
What do you get when you combine the scalability and reliability of IBM mainframe servers with the flexibility and open standards of Linux? Measurable business value.
→ Get started with Linux on IBM System z

Featured topics

- IBM and Business Partners Realize Significant Growth on the Mainframe and Linux
IBM announced a mainframe milestone as more than 390 IBM business partners now offer nearly 1,000 applications for System z customers running Linux, a 100 percent increase over the last year. IBM recently reported a 30 percent year-to-year growth of mainframe customers running Linux and this surge is giving IBM's channel partners the opportunity to capitalize on the mainframe's continued growth.
- IBM System z9 and Oracle plan to bring new Linux solutions to market
Oracle is extending the portfolio of products available on the IBM System z9 platform with a comprehensive set of both database and application solutions which Oracle intends to enable for Linux on System z. This could mean new opportunities for you to take advantage of the advanced functionality of Oracle applications on a premier Linux environment, benefiting from the core strengths of the IBM System z9 platform.
- Extreme virtualization & Linux
Listen how Nationwide, a Fortune 100 insurance and financial services company, embarked on a journey to aggressively exploit virtualization and Linux to address the growing software and data center costs, to simplify the environment, and to significantly improve the provisioning process.

Country/region [select] Terms of use Search

Home Products Services & solutions Support & downloads My account

IBM Systems > System z > z/VM >

z/VM®

the newest VM hypervisor based on 64-bit z/Architecture.

Currently supported releases of z/VM

Available:	z/VM V5.3
Also supported:	z/VM V5.2
	z/VM V5.1

The z/VM hypervisor is designed to help clients extend the business value of mainframe technology across the enterprise by integrating applications and data while providing exceptional levels of availability, security, and operational ease. z/VM virtualization technology is designed to allow the capability for clients to run hundreds to thousands of Linux servers on a single mainframe running with other System z operating systems, such as z/OS, or as a large-scale Linux-only enterprise server solution. z/VM V5.3 can also help to improve productivity by hosting non-Linux workloads such as z/OS, z/VSE, and z/TPF.

Summary of News and Updates

View 07 Aug. 2007 updates.
Read the z/VM and VM Site News and Changes for a summary of VM-related news, announcements, pointers, new classes, and places to hear about z/VM virtualization technology.

Worldwide announcement letters (US letters / product links below)

- Jun. 12, 2007 IBM Integrated Removable Media Manager (IRMM)
- Jun. 12, 2007 IBM z/VM V5.3 - Additional enhancements available
- Apr. 18, 2007 z9 EC and z9 BC - delivering greater value for everyone
- Feb. 06, 2007 IBM z/VM V5.3 - Improving scalability, security, and virtualization technology
- Apr. 27, 2006 z/VM V5.2 New Function Added in Support of System z9
- Apr. 27, 2006 Introducing new members to the System z9™ family
- Aug. 15, 2005 V1.2.0 IBM Backup and Restore Manager for z/VM
- Feb. 21, 2006 V1.2.0 Tape Manager & Operations Manager for z/VM
- Dec. 16, 2005 z/VM V5.2 Generally Available
- Aug. 23, 2005 Archive Manager and Operations Manager for z/VM

Linux on System z at developerWorks

ibm.com/developerworks/linux/linux390

The screenshot shows the IBM developerWorks website. At the top, there is a navigation bar with the IBM logo, a search bar, and a dropdown menu for 'Country/region'. Below the navigation bar, there is a breadcrumb trail: '← developerWorks'. The main content area is titled 'Linux on System z' and contains several sections: 'What's new', 'Kernel 2.6 based', 'Kernel 2.4 based', 'Kernel 2.2 based', 'Useful add-ons', 'Tuning hints & tips', 'How to', and 'Feedback'. The 'What's new' section lists several links: 'What is Linux?', 'What is Linux for S/390 and Linux for zSeries?', 'Why did IBM contribute S/390 and zSeries support for Linux?', 'How to get the source', and 'Get involved'. The 'How to' section has a sub-section 'What is Linux?' which contains a paragraph of text about Linux. Below this is another sub-section 'What is Linux for S/390 and Linux for zSeries?' which contains a paragraph of text about Linux for S/390 and zSeries. At the bottom of the page, there is a 'Back to top' link.

Country/region [select] | Terms of use

All of dW [dropdown] Search

Home | Products | Services & industry solutions | Support & downloads | My IBM

← developerWorks

Linux on System z

What's new

Kernel 2.6 based

Kernel 2.4 based

Kernel 2.2 based

Useful add-ons

Tuning hints & tips

How to

Feedback

Linux on System z

Document options

Print this page

E-mail this page

Contact the IBM team

If you want to contact the Linux on zSeries IBM team refer to the Contact the Linux on zSeries IBM team page

What is Linux?

Linux is an operating system whose kernel was developed by Linus Torvalds and initially distributed in 1991. Linux has evolved to become a widely accepted operating system with a wealth of applications. Today, many Linux distributions also contain a variety of tools and utilities provided by the open source community (e.g., from the GNU project). Linux is platform-independent and executes on many architectures, including Intel®, Alpha®, or Sparc®. Linux is Open Source software that may be downloaded free of charge. You can learn more about Open Source [here](#).

Back to top

What is Linux for S/390 and Linux for zSeries?

Linux for S/390® and zSeries® is a port of Linux to the S/390 and zSeries architecture. Linux for S/390 and zSeries is a "pure" Linux from a user point of view. It supports the S/390 and zSeries processor architecture and devices that are specific to S/390 and zSeries environments. Therefore Linux for S/390 and Linux for zSeries automatically inherits important strengths and reliability features of the S/390 and zSeries hardware.

For more technical details, please click on

- kernel 2.6 based streams:
 - October 2005 stream
 - April 2004 stream
- kernel 2.4 based streams:
 - June 2003 stream
 - May 2002 stream (superseded by "June 2003 stream")
 - August 2001 stream
- kernel 2.2 based Technical details

You can find the official Linux on System z homepage at <http://www.ibm.com/s390/linux>.

Back to top

Internet list server discussions

■ IBMVM discusses z/VM

- To subscribe, send a note to listserv@listserv.uark.edu. In the body of the note, write only the following line:
 - **SUBSCRIBE IBMVM** *firstname lastname*
- View and search the current list and archives:
 - <http://listserv.uark.edu/archives/ibmvm.html>

■ LINUX-390 discusses Linux on System z

- To subscribe, send a note to listserv@vm.marist.edu. In the body of the note, write only the following line:
 - **SUBSCRIBE LINUX-390** *firstname lastname*
- View and search the current list and archives:
 - <http://www.marist.edu/htbin/wlvindex?linux-390>

Mark Post's Linux for Big Iron site

linuxvm.org



Last updated on:
Saturday February 3, 2007

Software

- [Linux/390 Distributions](#)
- [Linux/390 Patches](#)
- [Hercules](#) - An S/390 Hardware Emulator

Linux for S/390

Linux for Big Iron

Linux for S/390 and zSeries, also known as Linux/390, is the native port of Linux to the S/390 and zSeries hardware platforms. It runs on the bare hardware, in an LPAR and as a VM, or z/VM guest.

LinuxVM.org is the official home of the Linux/390 project. The purpose of the project is to provide a central source of Linux/390 information and software, and to explore the possibilities of Linux and CP integration or interoperation.

The list of Linux/390 Redbooks was getting a little too unwieldy to remain on the front page, so it has been moved to its [own page](#).

01/26/2007 - A new Linux Kernel mailing list has been set up at vger.kernel.org for anyone that is interested in following or participating in mainframe Linux development. The traffic will consist mostly of technical discussions about kernel development for the mainframe platform. You can subscribe at the link below.

<http://vger.kernel.org/vger-lists.html#linux-s390>

<http://www2.marist.edu/htbin/wlvttype?LINUX-VM.64285>

Additional web sites

- **z/VM resources for Linux on IBM System z**
 - ibm.com/vm/linux
- **Wikipedia**
 - wikipedia.org/wiki/Linux_on_zSeries
- **General z/VM tuning tips**
 - ibm.com/vm/perf/tips
- **Linux distributions for System z**
 - Novell SUSE Linux Enterprise at novell.com/products/server/
 - Red Hat Enterprise Linux at redhat.com/rhel/details/servers/

Thank you

Jim Elliott

Consulting Sales Specialist – System z
Product Manager – System z Operating Systems

IBM Canada Ltd.

jim_elliott@ca.ibm.com

905-316-5813

ibm.com/linux

ibm.com/systems/z

ibm.com/vm/devpages/jelliott

Notices

© Copyright IBM Corporation 2000, 2007. All rights reserved.

This document contains words and/or phrases that are trademarks or registered trademarks of the International Business Machines Corporation in the United States and/or other countries. For information on IBM trademarks go to <http://www.ibm.com/legal/copytrade.shtml>.

The following are trademarks or registered trademarks of other companies.

Java and all Java-related trademarks and logos are trademarks of Sun Microsystems, Inc., in the United States and other countries.

UNIX is a registered trademark of The Open Group in the United States and other countries.

Microsoft, Windows and Windows NT are registered trademarks of Microsoft Corporation.

Red Hat, the Red Hat "Shadow Man" logo, and all Red Hat-based trademarks and logos are trademarks or registered trademarks of Red Hat, Inc., in the United States and other countries.

Linux is a trademark of Linus Torvalds in the United States, other countries, or both.

All other products may be trademarks or registered trademarks of their respective companies.

Notes:

This publication was produced in Canada. IBM may not offer the products, services or features discussed in this document in other countries, and the information may be subject to change without notice. Consult your local IBM business contact for information on the product or services available in your area.

All statements regarding IBM's future direction and intent are subject to change or withdrawal without notice, and represent goals and objectives only.

Information about non-IBM products is obtained from the manufacturers of those products or their published announcements. IBM has not tested those products and cannot confirm the performance, compatibility, or any other claims related to non-IBM products. Questions on the capabilities of non-IBM products should be addressed to the suppliers of those products.

Prices subject to change without notice. Contact your IBM representative or Business Partner for the most current pricing in your geography.

Permission is hereby granted to SHARE to publish an exact copy of this paper in the SHARE proceedings. IBM retains the title to the copyright in this paper as well as title to the copyright in all underlying works. IBM retains the right to make derivative works and to republish and distribute this paper to whomever it chooses in any way it chooses.