



| Linux @ IBM

Linux on IBM eServer – POWER and zSeries

SHARE Session 9202



Jim Elliott, Linux Advocate
Strategic Growth Initiatives
IBM Canada Ltd.

Linux



SHARE Session 9202

August 16, 2004

© 2004 IBM Corporation

Linux on IBM eServer – POWER and zSeries

- **IBM provides a broad range of support for Linux with hardware, software and services.**
- **Jim Elliott, IBM's Linux Advocate, will provide a overview of Linux on the IBM eServer products, with a focus on POWER and zSeries.**
- **The session will provide a comparison of Linux and supporting solutions on these platforms with the goal of helping users in making a platform selection.**
- **Jim will also provide an overview of IBM's Virtualization Engine solutions which are designed to enhance management of the infrastructure.**

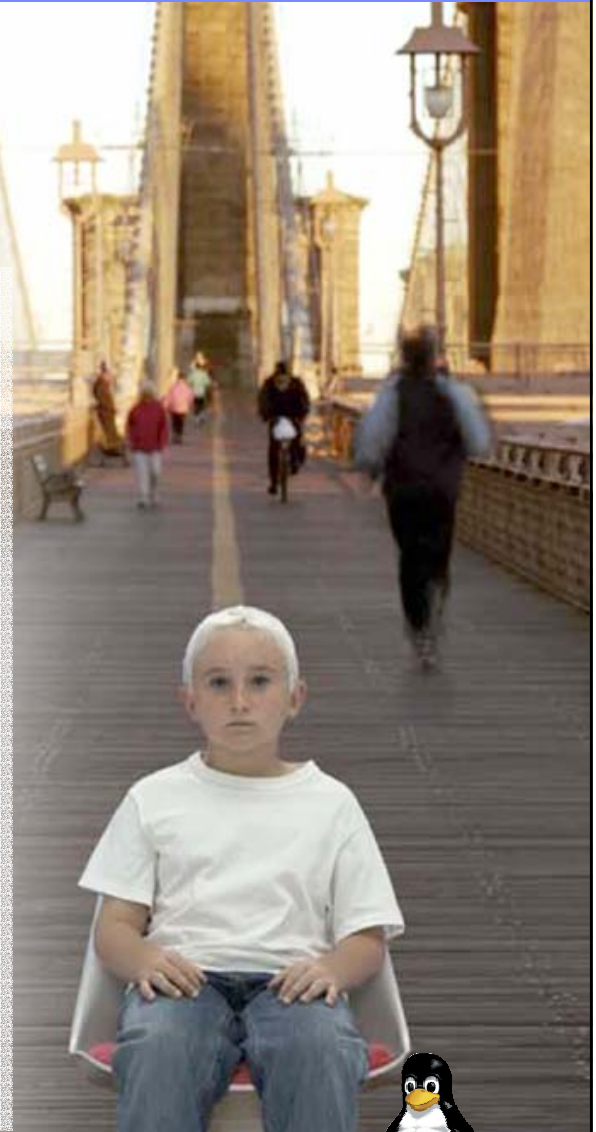



| Linux @ IBM

Linux on IBM eServer

Linux



SHARE Session 9202

August 16, 2004

© 2004 IBM Corporation

Taking Linux mainstream

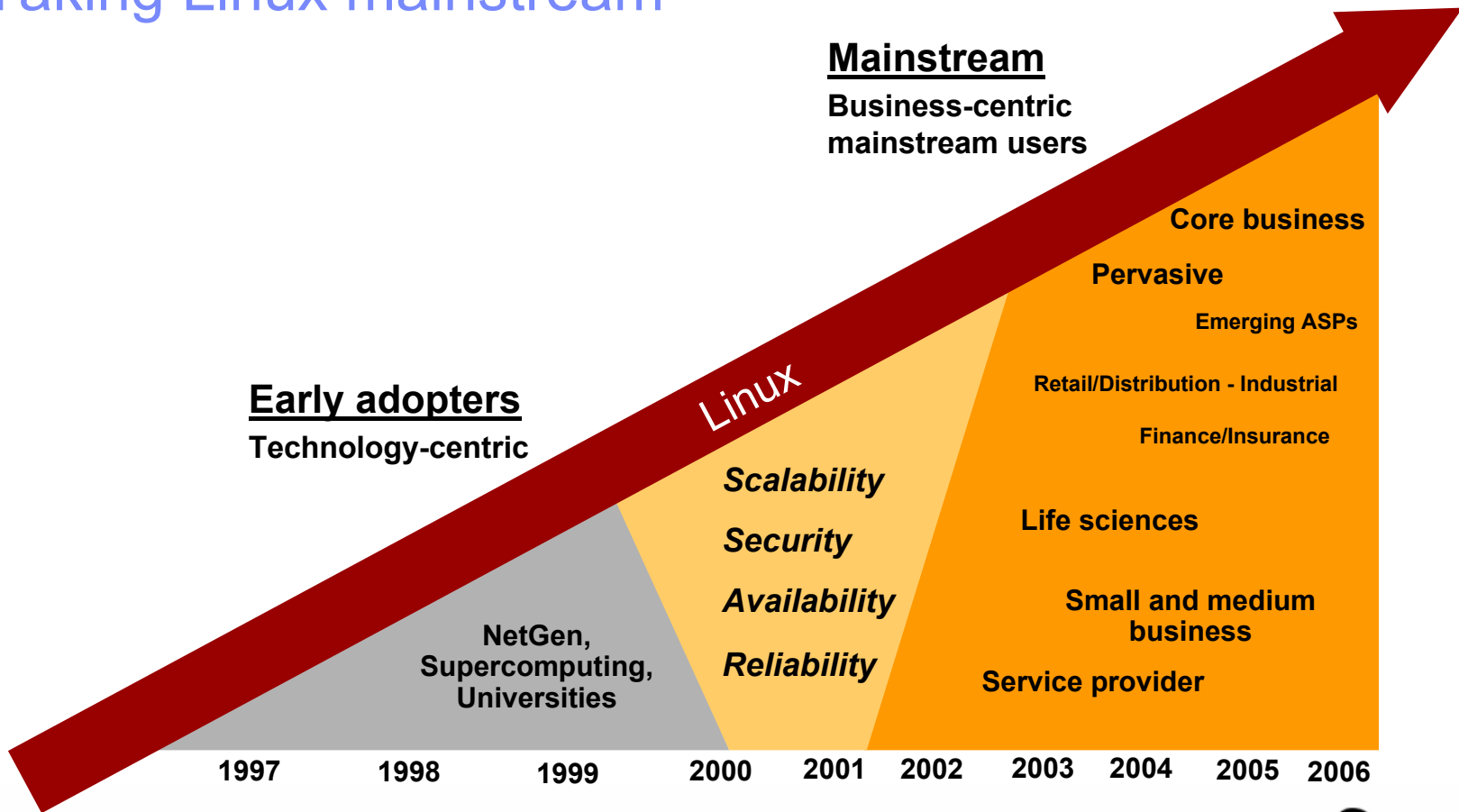

Linux technology evolution – Reasons for going mainstream

2.4

Future (2.6 and beyond)



- Efficient 4-way SMP scalability
- 64-bit support
- Multi-tasking
- 1TB file size, Journaling
- Clustering
- IBM eServer partition support
- Enhanced RAS
- Advanced networking
- Linux standards base

Recertification

- 16-way+ scalability
- I/O & file system performance
- Security enhancements
- Hyperthreading performance enhancements
- Kernel & driver 'hardening'
- Pre-emptive Kernel
- Improved Scheduler
- Large Page Support
- VM Enhancements
- Block I/O
- Sub-processor partitioning support

This represents a combination of current open source community priorities and IBM LTC project plans. Open source communities do not publish schedules or commit to specific dates or functions.



IBM eServer and Linux

ibm.com/eserver/linux

- **IBM eServer zSeries**
 - Hundreds of Linux servers
 - Integration with z/OS
- **IBM eServer iSeries / i5**
 - Up to 254 Linux partitions
 - Integration with OS/400
- **IBM eServer pSeries / p5**
 - Up to 254 Linux partitions
 - Linux affinity in AIX 5L
- **IBM eServer xSeries**
 - X-architecture innovation
 - Freedom of choice
 - IA32, EM64T, IA64
- **IBM eServer 325**
 - AMD Opteron
- **IBM eServer Clusters**
 - Component integration
 - Speed to market
- **IBM eServer Blades**
 - High density servers
 - Integrated components





| Linux @ IBM

IBM Virtualization Engine

Linux



SHARE Session 9202

August 16, 2004

© 2004 IBM Corporation

IBM Virtualization Engine

- **Enables individual distributed resources across the enterprise (servers, storage, networking) to function cohesively as a single pool or entity**
- **Allows more efficient access and management of resources across an organization by effect and need rather than physical location**
- **Components**
 - IBM Virtualization Engine Systems Technologies
 - IBM Virtualization Engine Suite for Servers
 - IBM Virtualization Engine Suite for Storage



IBM Virtualization Engine Systems Technologies

- **Technologies integrated and delivered with certain IBM eServer servers**
- **Partitioning software**
 - z/VM on zSeries
 - Advanced POWER Virtualization on i5 and p5
 - Micro-Partitioning
 - Virtual LAN, I/O
 - VMware on xSeries, e325, and BladeCenter
- **Partitioning firmware**
 - PR/SM LPAR on zSeries with Intelligent Resource Director
 - LPAR on iSeries and pSeries



IBM Virtualization Engine Suite for Servers

- **IBM Enterprise Workload Manager**
 - Provides end-to-end resource optimization and load balancing of IT resources in heterogeneous, multi-tier application and server environment
- **IBM Director Multiplatform**
 - Acts as a single point of control for enabled IBM hardware platform portfolio for servers and storage
- **IBM Tivoli Provisioning Manager**
 - Can help increase average utilization of resources



IBM Virtualization Engine Suite for Servers ...

- **IBM Grid Toolbox V3 for Multiplatforms**
 - A comprehensive, integrated toolkit for creating and hosting grid services
- **Virtualization Engine Console**
 - A Web-based console that provides a consolidated view of enabled enterprise resources
- **Packaging**
 - A single product with different levels of function on different platforms



IBM Virtualization Engine Suite for Servers

■ Statement of Direction

- In the future, IBM intends to extend Virtualization Engine systems services capabilities to additional platforms including zSeries' flagship operating system, z/OS, as well as Linux for zSeries.
- Delivering additional cross platform support is expected to broaden the optimization, virtualization, and infrastructure management capabilities across the IT environment for all IBM servers. The systems services may be delivered in updates to the current release of the IBM Virtualization Engine Suite for Servers or in future versions of the product.



IBM Virtualization Engine Suite for Storage

<http://www.storage.ibm.com/software/>

- **IBM TotalStorage SAN Volume Controller**
 - Enables storage virtualization and can help increase the utilization of existing capacity
- **IBM TotalStorage SAN File System**
 - Provides a network-based heterogeneous file system for data sharing and policy-based storage management in an open environment
- **IBM TotalStorage Productivity Center**
 - Simplifies the management of traditional and virtualized SAN environments
- **Packaging**
 - Delivered as separate products, the TotalStorage elements are part of the IBM TotalStorage Open Software Family





| Linux @ IBM

Linux on POWER

Linux



SHARE Session 9202

August 16, 2004

© 2004 IBM Corporation

IBM Virtualization Engine Systems Technologies

- **POWER Hypervisor**
- **Simultaneous multi-threading (SMT)**
- **LPAR and micro-partitioning**
- **Virtual LAN**
- **Virtual I/O**
- **Capacity on demand**
- **Multiple operating system support**



Virtualization technologies implemented on POWER5 servers

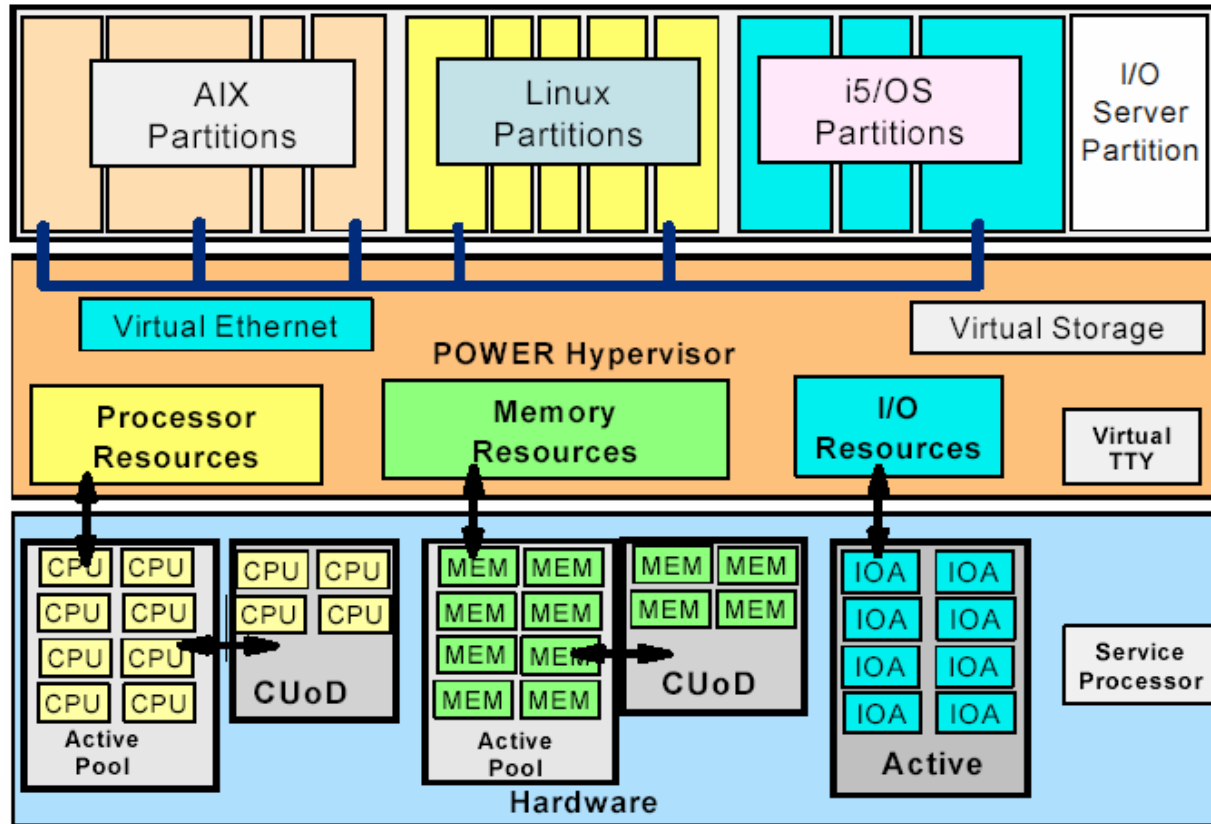

IBM's long term investment in POWER delivers

- **Collaborative Power Architecture**
 - Allows device designers, chip manufacturers, and other members of the community to work together on new and innovative applications
- **Technology leadership**
 - IBM Virtualization Engine systems technologies
 - Mainframe-inspired enterprise-class reliability, availability, scalability (RAS)
- **Over a Decade of experience**
 - Evolutionary approach with a roadmap to the future
 - Systems architecture expertise
- **64-bit performance**
 - Allows enterprise-class applications to be run on Linux



Linux on POWER: The passion of Linux enriched by the power of IBM

■ **Uncompromising Reliability**

- POWER provides high-performance 64-bit architecture to enable mission-critical workloads on Linux
- Enterprise-class reliability, availability and serviceability features help ensure your applications are running around the clock
- Depend on a stable POWER offering roadmap, Linux commitment and leadership service and support to give you peace of mind

■ **Sustainability of Price/Performance**

- Build on a platform of open industry standards that can scale-up or scale-out to support future growth and maintain business flexibility
- IBM Virtualization Engine systems technologies help improve resource utilization, reduce downtime, improve system management and lower costs

■ **Ecosystem Investments Delivering Value to the Market**

- Extensive investments in hardware accessibility
- Significant technical support to ensure portability
- Industry and Open Source Community support for POWER5



IBM eServer BladeCenter Linux on POWER

- **BladeCenter JS20 offers:**
 - Leading-edge price/performance with VMX technology
 - Reinforces BladeCenter value of integration
 - Low management and operational costs
 - New entry price point for POWER
 - 64-bit POWER at industry standard price

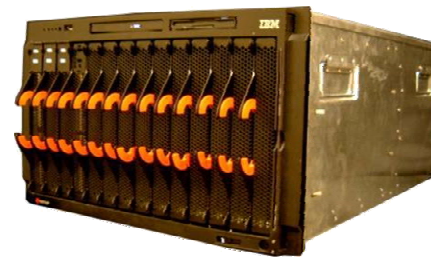

IBM eServer p5 family

- **p5-520 – Up to 2-way**
 - 1.65 GHz POWER5
 - Up to 32GB memory
 - Micro-Partitioning*
 - Virtual LAN, I/O*
- **p5-550 – Up to 4-way**
 - 1.65 GHz POWER5
 - Up to 64GB memory
 - Micro-Partitioning*
 - Virtual LAN, I/O*
- **p5-570**
 - ‘Pay as you grow’ modular architecture
 - True SMP [not NUMA]
 - Micro-Partitioning*
 - Virtual LAN, I/O*
- **p5-570 Express – Up to 8-way**
 - 1.5 GHz POWER5
 - Up to 256GB memory
- **p5-570 – Up to 16-way**
 - 1.65 GHz POWER5
 - 1.9 GHz POWER5
 - Up to 512GB memory

* Optional features



Linux on POWER5 systems are tuned for Linux

- **Linux 2.6 kernel and POWER5: an enhanced combination**

- Linux on POWER5 systems are tuned for Linux to take advantage of inherent characteristics of Power Architecture technology, designed to improve performance
 - Improved memory access, instruction / data cache coherency, synchronization and faster data lock acquisitions, etc
- The Linux kernel leverages POWER processors' performance features, designed to improve uptime and scalability
 - Support of large SMPs, First Failure Data Capture and HW diagnostics, etc.
- Linux exploits POWER processors' hardware-based IBM Virtualization Engine capabilities, designed to improve utilization, hence lower operational costs
 - Micro-Partitioning, dynamic LPARs, virtual I/O, virtual LAN, virtual storage, etc

Support varies by distribution.



Linux on POWER5: Flexible and stable technology with enterprise-class RAS

- **Flexibility and stability through POWER5 architecture**
 - Evolutionary approach with a roadmap to the future
 - System innovation leveraging a decade of experience
 - Runs 32-bit and 62-bit applications
- **RAS designed and engineered for Linux from the ground up**
 - First Failure Data Capture
 - Dynamic Processor Deallocation¹
 - LPAR error containment
 - Service processor
 - Double data rate (DDR) IBM Chipkill memory
 - Error-correcting code (ECC) memory

¹ Linux on POWER with SUSE LINUX Enterprise Server 9 (SLES 9).



Linux on POWER foundation applications

- **IBM Software Group**
 - Full complement of core software from WebSphere, DB2, Tivoli, Informix
 - Key IBM compilers, cluster Management
- **ISV Infrastructure and Tools**
 - BEA Weblogic Server, MySQL DB, Bakbone, NetVault, BMC Patrol Agent & KMs, Novell, Accucorp, Myricom, Storix, Platform Computing, ...
- **Open source Infrastructure and Tools**
 - Apache, SAMBA, Sendmail, others
 - Distributed with Red Hat and Novell SUSE
- **Workload Applications**
 - Deep Computing – growing portfolio of Life Sciences, Petroleum and open source applications
 - SAP committed support in 2004
- **Industry and Regional Applications**
 - Temonos, Fair Isaac, Genaware, Hansa, Tecsys, Evant, eOne, Triversity, ...

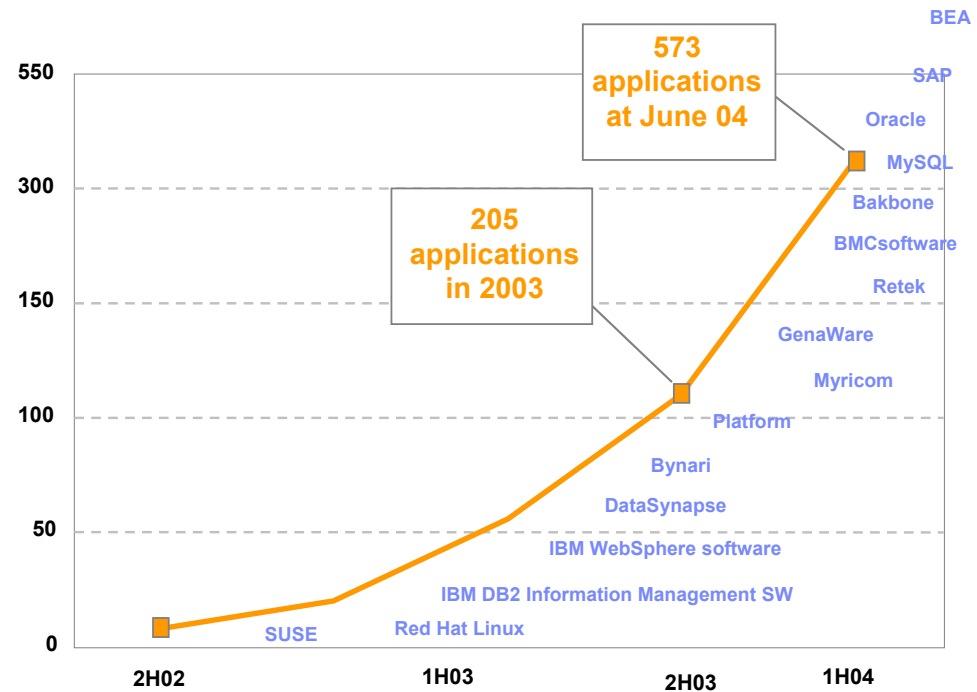

Linux on POWER technology

- **Linux**
 - Fastest-growing operating environment
 - Provides unmatched versatility
 - A cost-effective, security-rich environment, powerful enough to run business-critical applications
 - Hundreds of applications available
- **Plus POWER**
 - A unifying architecture featuring the most innovative chip available
 - Exceptional reliability, availability and serviceability — and the scalability you need to power your business
 - IBM Virtualization Engine enables consistent management of heterogeneous environments
- **Equals Linux on POWER**
 - Great today, even better tomorrow
 - A clear path for the future, backed by an industry leader





Linux @ IBM

Linux on zSeries

Linux



SHARE Session 9202

August 16, 2004

© 2004 IBM Corporation

What is Linux on zSeries?

- **A native zSeries operating environment**

- Exploits IBM zSeries hardware
- Not a unique version of Linux

- **zSeries application sourcing strategy**

- The IBM commitment to z/OS is not affected by this Linux strategy
- zSeries customers are offered additional opportunities to leverage their investments through Linux
- New doors are opening for zSeries customers to bring Linux-centric workloads to the platform

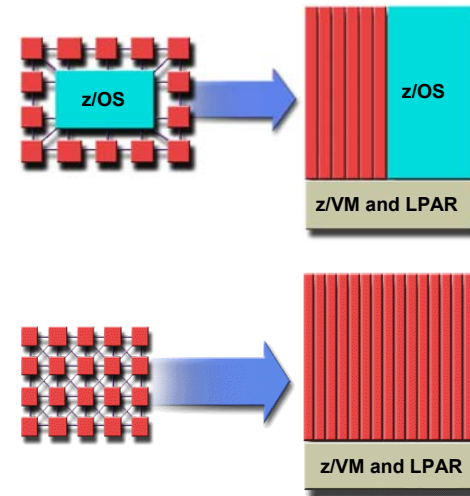

Why Linux on zSeries?

- 1. Increased solutions through Linux application portfolio**
- 2. Large number of highly skilled programmers familiar with Linux**
- 3. Integrated business solutions**
 - Data richness from zSeries
 - Wide range of Linux applications
- 4. Industrial strength environment**
 - Flexibility and openness of Linux
 - Qualities of service of zSeries
- 5. Unique ability to easily consolidate large number of servers**



What zSeries brings to Linux

- **Extensive hardware support**
 - Up to 32 central processors and up to 8 I/O processors
 - Cryptographic support
 - Traditional and Open I/O subsystems
- **Centralized Linux systems are easier to manage**
- **Designed to support mixed work loads**
 - Allows consolidation while maintaining one server per application
 - Complete work load isolation
 - High speed inter-server connectivity



Value of Linux on zSeries

- **Reduced Total Cost of Ownership (TCO)**
 - Environmental savings - single footprint vs. hundreds of servers
 - Consolidation savings - less storage, less servers, less software licenses, less server management/support
- **Improved service level**
 - Systems management (single point of control)
 - Reliability, availability, security of zSeries hardware and z/VM software
 - High performance integration with z/OS
- **Speed to market**
 - Capacity-on-demand capability on zSeries
 - Dynamic allocation of on-line users, less than 10 seconds to add a new Linux server image using z/VM and ESS



Infrastructure Simplification

- Customers leveraging scale up and scale out technologies to simplify and integrate their on demand operating environment
- As one solution option:
 - Mainframes/Blades integrated with Linux, Java and Grid technologies can enable this transformation

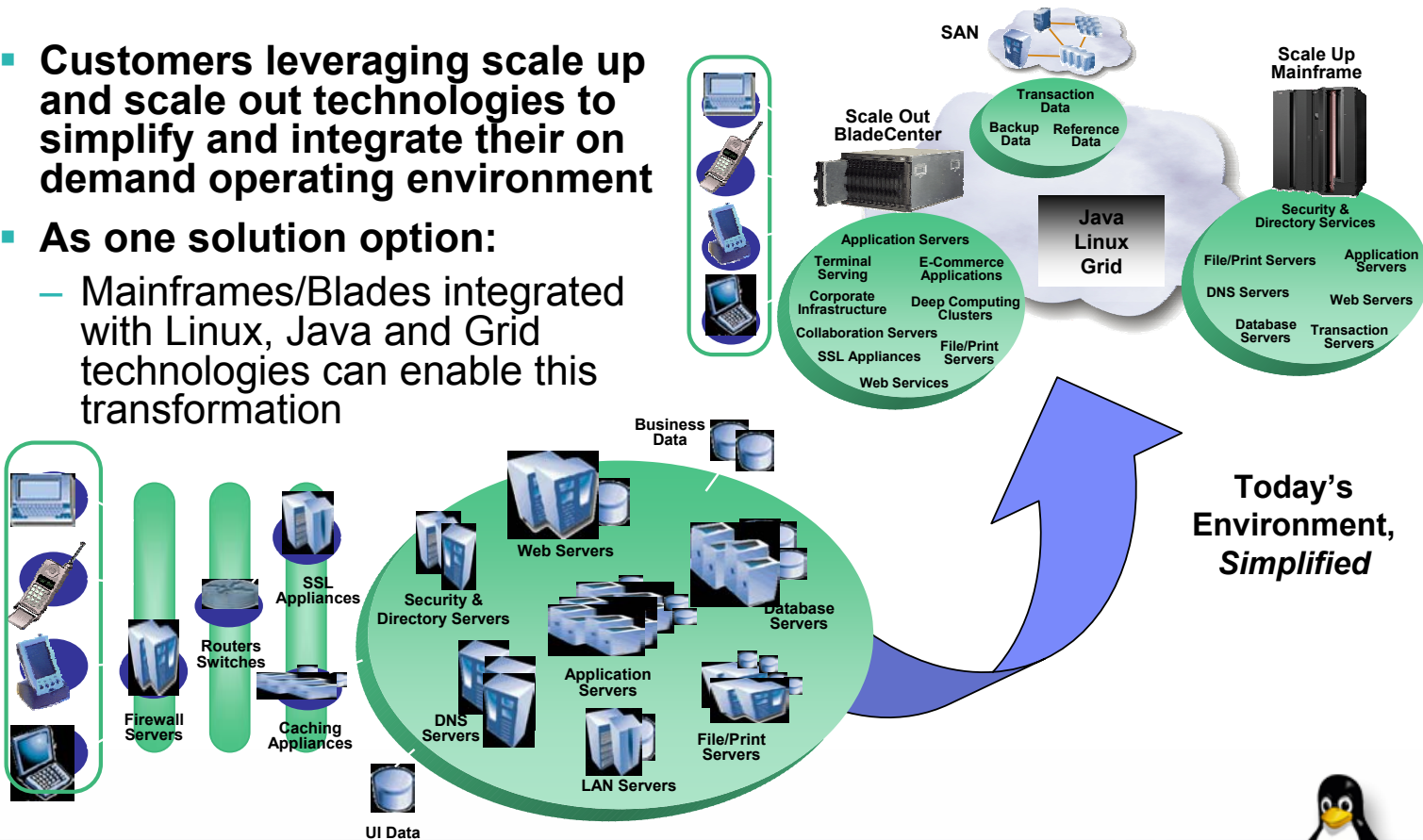

Discrete vs. consolidated

Discrete servers	Consolidated solution
Larger support staffs are required to maintain servers and network gear	Smaller support staffs are required to maintain 1 or 2 servers
Disaster recovery very difficult for large / complex server farms	Disaster recovery very easy for virtual server farms
Lower hardware reliability	Higher hardware reliability
Software resource must be duplicated for each server	Software resource shared among virtual servers
Higher software application cost due to more hardware processors	Lower software application cost due to fewer hardware processors
Failover is provided by additional server hardware in "hot standby mode"	Failover is provided by virtual server in "hot standby mode"
Discrete servers may require significant amounts of power and floor space	Server and disk storage subsystem require minimal power and floor space

Virtualization Engine Systems Technologies

- **Logical Partitions (LPAR)**

- Hardware partitioning enabling up to 30 “logical partitions” each of which runs a separate operating system – traditional operating systems and Linux

- **Virtual Partitions (z/VM)**

- zSeries virtualization technology – developed over 37+ years
- Support for large numbers of Linux images with rich system management capabilities
- Very flexible, great for server consolidation
- Best RAS characteristics



zSeries Integrated Facility for Linux

- **Additional engines dedicated to Linux workloads**
 - Supports z/VM and Linux on zSeries
- **Traditional zSeries software charges unaffected**
 - IBM zSeries and S/390 software
 - Independent Software Vendor products
- **Linux and z/VM charged only against the IFLs**

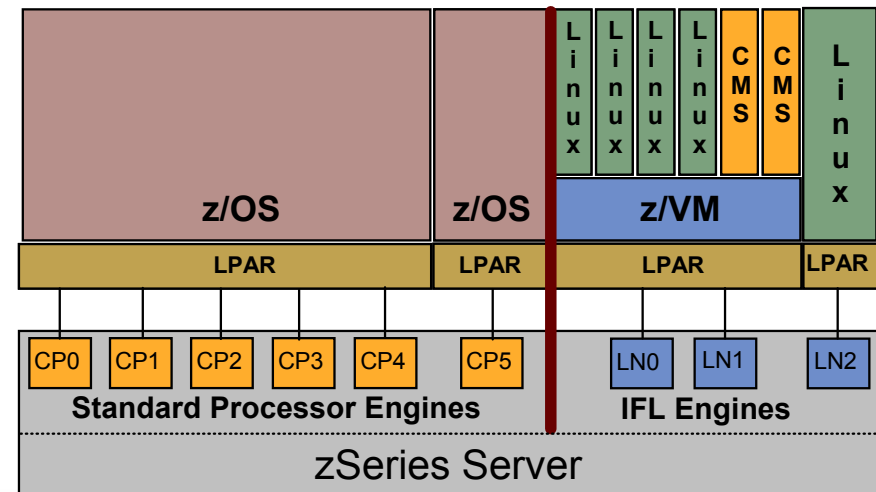

The value of z/VM for Linux

- **Enhanced performance, growth and scalability**
 - Server consolidation enables horizontal growth
 - N-tier architecture on two tiers of hardware
 - Extensive support for sharing resources
 - Virtual networking
 - Effective isolation of Linux images, if required
- **Increased productivity**
 - Development and testing
 - Production support
- **Improved operations**
 - Backup and recovery
 - Command and control

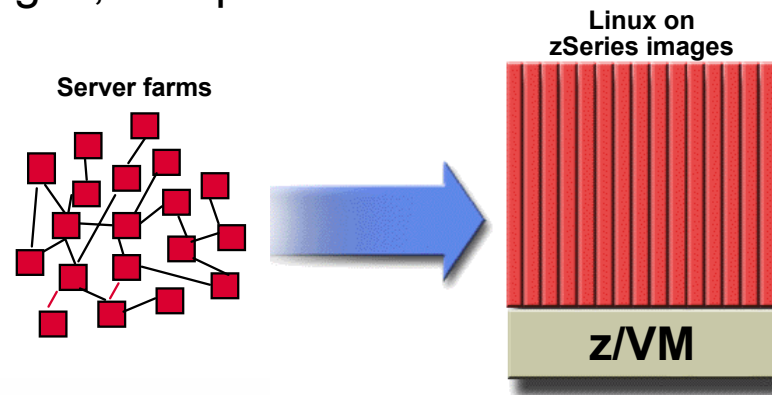

Application serving with Linux on zSeries

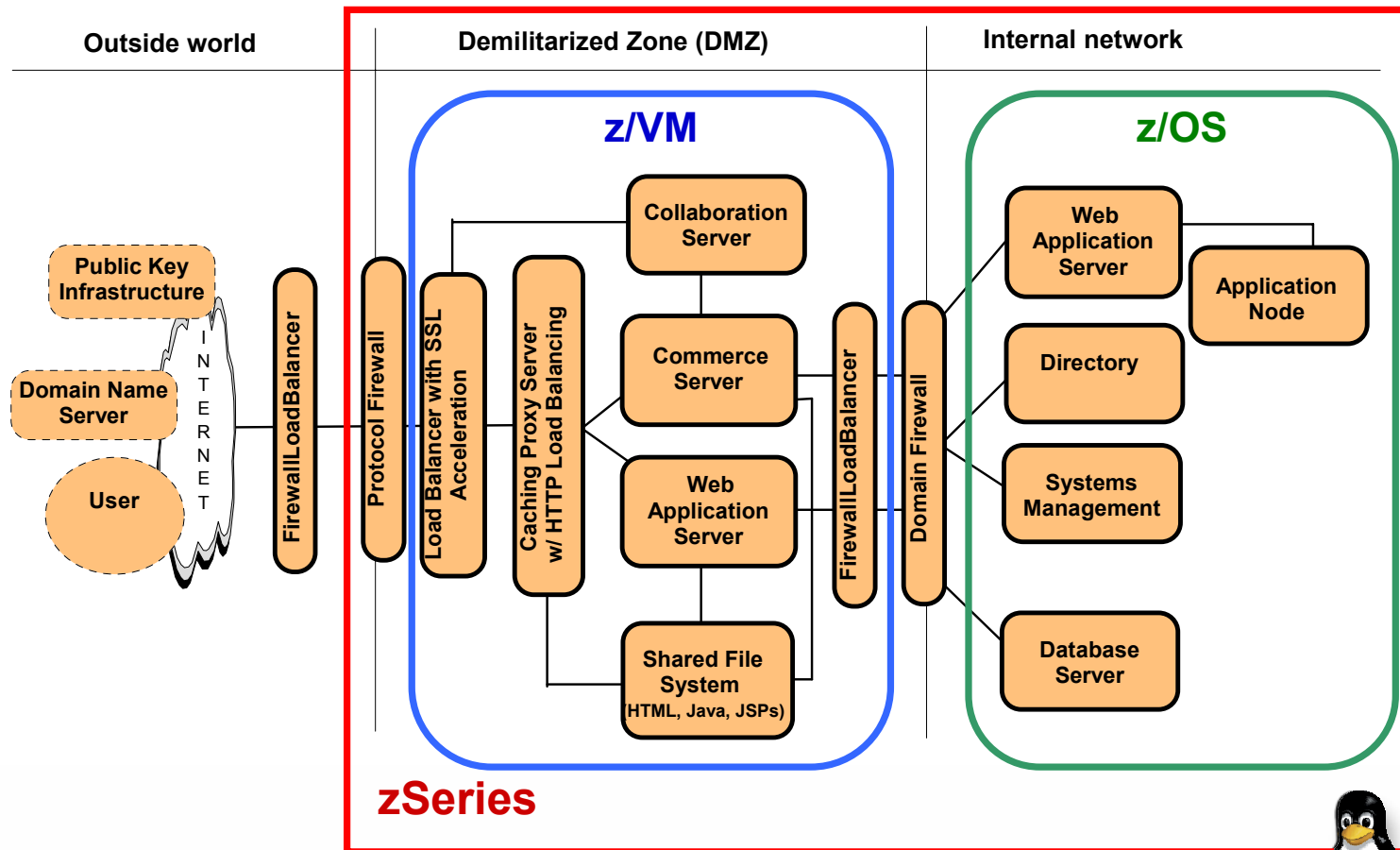

Jim Elliott, Advocate
IBM Corporate Linux
IBM Canada Ltd.
jim_elliott@ca.ibm.com

Recommendations

- **Familiarize yourself with Linux**
- **View Linux as a valid alternative for IT systems**
- **Incorporate open source software development into IT strategies**
- **Look at Linux to see how it can:**
 - Lower costs
 - Increase reliability and security
 - Improve service

ON DEMAND BUSINESS



LINUX IS EVERYWHERE



Notices

- **© Copyright IBM Corporation 2000, 2004. All rights reserved.**
- **This document contains words and/or phrases that are trademarks or registered trademarks of the International Business Machines Corporation in the United States and/or other countries. For information on IBM trademarks go to <http://www.ibm.com/legal/copytrade.shtml>.**
- **The following are trademarks or registered trademarks of other companies.**
 - Java and all Java-related trademarks and logos are trademarks of Sun Microsystems, Inc., in the United States and other countries.
 - UNIX is a registered trademark of The Open Group in the United States and other countries.
 - Microsoft, Windows and Windows NT are registered trademarks of Microsoft Corporation.
 - Red Hat, the Red Hat "Shadow Man" logo, and all Red Hat-based trademarks and logos are trademarks or registered trademarks of Red Hat, Inc., in the United States and other countries.
 - Linux is a trademark of Linus Torvalds in the United States, other countries, or both.
- **All other products may be trademarks or registered trademarks of their respective companies.**
- **Notes:**
 - This publication was produced in Canada. IBM may not offer the products, services or features discussed in this document in other countries, and the information may be subject to change without notice. Consult your local IBM business contact for information on the product or services available in your area.
 - All statements regarding IBM's future direction and intent are subject to change or withdrawal without notice, and represent goals and objectives only.
 - Information about non-IBM products is obtained from the manufacturers of those products or their published announcements. IBM has not tested those products and cannot confirm the performance, compatibility, or any other claims related to non-IBM products. Questions on the capabilities of non-IBM products should be addressed to the suppliers of those products.
 - Prices subject to change without notice. Contact your IBM representative or Business Partner for the most current pricing in your geography.
- **Permission is hereby granted to SHARE to publish an exact copy of this paper in the SHARE proceedings. IBM retains the title to the copyright in this paper as well as title to the copyright in all underlying works. IBM retains the right to make derivative works and to republish and distribute this paper to whomever it chooses in any way it chooses.**